

2 Quadratic Functions

- 2.1 Transformations of Quadratic Functions
- 2.2 Characteristics of Quadratic Functions
- 2.3 Focus of a Parabola
- 2.4 Modeling with Quadratic Functions



Meteorologist (p. 77)



Electricity-Generating Dish (p. 71)



Gateshead Millennium Bridge (p. 64)



Soccer (p. 63)



Kangaroo (p. 53)

Maintaining Mathematical Proficiency

Finding x-Intercepts

Example 1 Find the x -intercept of the graph of the linear equation $y = 3x - 12$.

$$y = 3x - 12$$

Write the equation.

$$0 = 3x - 12$$

Substitute 0 for y .

$$12 = 3x$$

Add 12 to each side.

$$4 = x$$

Divide each side by 3.

▶ The x -intercept is 4.

Find the x -intercept of the graph of the linear equation.

1. $y = 2x + 7$

2. $y = -6x + 8$

3. $y = -10x - 36$

4. $y = 3(x - 5)$

5. $y = -4(x + 10)$

6. $3x + 6y = 24$

The Distance Formula

The distance d between any two points (x_1, y_1) and (x_2, y_2) is given by the formula

$$d = \sqrt{(x_2 - x_1)^2 + (y_2 - y_1)^2}.$$

Example 2 Find the distance between $(1, 4)$ and $(-3, 6)$.

Let $(x_1, y_1) = (1, 4)$ and $(x_2, y_2) = (-3, 6)$.

$$d = \sqrt{(x_2 - x_1)^2 + (y_2 - y_1)^2}$$

Write the Distance Formula.

$$= \sqrt{(-3 - 1)^2 + (6 - 4)^2}$$

Substitute.

$$= \sqrt{(-4)^2 + 2^2}$$

Simplify.

$$= \sqrt{16 + 4}$$

Evaluate powers.

$$= \sqrt{20}$$

Add.

$$\approx 4.47$$

Use a calculator.

Find the distance between the two points.

7. $(2, 5), (-4, 7)$

8. $(-1, 0), (-8, 4)$

9. $(3, 10), (5, 9)$

10. $(7, -4), (-5, 0)$

11. $(4, -8), (4, 2)$

12. $(0, 9), (-3, -6)$

13. **ABSTRACT REASONING** Use the Distance Formula to write an expression for the distance between the two points (a, c) and (b, c) . Is there an easier way to find the distance when the x -coordinates are equal? Explain your reasoning.

Mathematical Practices

Mathematically proficient students distinguish correct reasoning from flawed reasoning.

Using Correct Logic

Core Concept

Deductive Reasoning

In *deductive reasoning*, you start with two or more statements that you know or assume to be true. From these, you *deduce* or *infer* the truth of another statement. Here is an example.

1. **Premise:** If this traffic does not clear, then I will be late for work.
2. **Premise:** The traffic has not cleared.
3. **Conclusion:** I will be late for work.

This pattern for deductive reasoning is called a *syllogism*.

EXAMPLE 1 Recognizing Flawed Reasoning

The syllogisms below represent common types of *flawed reasoning*. Explain why each conclusion is not valid.

- | | |
|--|---|
| a. When it rains, the ground gets wet.
The ground is wet.
Therefore, it must have rained. | b. When it rains, the ground gets wet.
It is not raining.
Therefore, the ground is not wet. |
| c. Police, schools, and roads are necessary.
Taxes fund police, schools, and roads.
Therefore, taxes are necessary. | d. All students use cell phones.
My uncle uses a cell phone.
Therefore, my uncle is a student. |

SOLUTION

- The ground may be wet for another reason.
- The ground may still be wet when the rain stops.
- The services could be funded another way.
- People other than students use cell phones.

Monitoring Progress

Decide whether the syllogism represents correct or flawed reasoning. If flawed, explain why the conclusion is not valid.

- | | |
|--|--|
| 1. All mammals are warm-blooded.
All dogs are mammals.
Therefore, all dogs are warm-blooded. | 2. All mammals are warm-blooded.
My pet is warm-blooded.
Therefore, my pet is a mammal. |
| 3. If I am sick, then I will miss school.
I missed school.
Therefore, I am sick. | 4. If I am sick, then I will miss school.
I did not miss school.
Therefore, I am not sick. |

Mathematical Practices

Mathematically proficient students *distinguish correct logic or reasoning from that which is flawed.* (MP3)

Using Correct Logic

Core Concept

Deductive Reasoning

In *deductive reasoning*, you start with two or more statements that you know or assume to be true. From these, you *deduce* or *infer* the truth of another statement. Here is an example.

1. **Premise:** If this traffic does not clear, then I will be late for work.
2. **Premise:** The traffic has not cleared.
3. **Conclusion:** I will be late for work.

This pattern for deductive reasoning is called a *syllogism*.

EXAMPLE 1 Recognizing Flawed Reasoning

The syllogisms below represent common types of *flawed reasoning*. Explain why each conclusion is not valid.

- | | |
|--|---|
| a. When it rains, the ground gets wet.
The ground is wet.
Therefore, it must have rained. | b. When it rains, the ground gets wet.
It is not raining.
Therefore, the ground is not wet. |
| c. Police, schools, and roads are necessary.
Taxes fund police, schools, and roads.
Therefore, taxes are necessary. | d. All students use cell phones.
My uncle uses a cell phone.
Therefore, my uncle is a student. |

SOLUTION

- The ground may be wet for another reason.
- The ground may still be wet when the rain stops.
- The services could be funded another way.
- People other than students use cell phones.

Monitoring Progress

Decide whether the syllogism represents correct or flawed reasoning. If flawed, explain why the conclusion is not valid.

- | | |
|--|--|
| 1. All mammals are warm-blooded.
All dogs are mammals.
Therefore, all dogs are warm-blooded. | 2. All mammals are warm-blooded.
My pet is warm-blooded.
Therefore, my pet is a mammal. |
| 3. If I am sick, then I will miss school.
I missed school.
Therefore, I am sick. | 4. If I am sick, then I will miss school.
I did not miss school.
Therefore, I am not sick. |

2.1 Transformations of Quadratic Functions

Essential Question How do the constants a , h , and k affect the graph of the quadratic function $g(x) = a(x - h)^2 + k$?

The parent function of the quadratic family is $f(x) = x^2$. A transformation of the graph of the parent function is represented by the function $g(x) = a(x - h)^2 + k$, where $a \neq 0$.

EXPLORATION 1 Identifying Graphs of Quadratic Functions

Work with a partner. Match each quadratic function with its graph. Explain your reasoning. Then use a graphing calculator to verify that your answer is correct.

- a. $g(x) = -(x - 2)^2$ b. $g(x) = (x - 2)^2 + 2$ c. $g(x) = -(x + 2)^2 - 2$
 d. $g(x) = 0.5(x - 2)^2 - 2$ e. $g(x) = 2(x - 2)^2$ f. $g(x) = -(x + 2)^2 + 2$

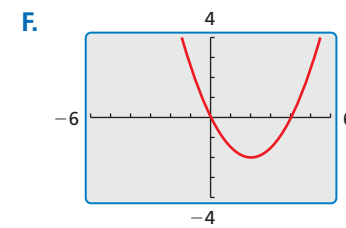
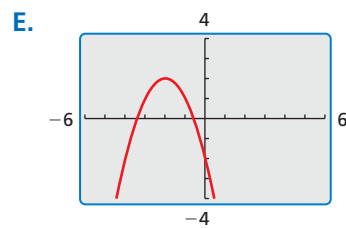
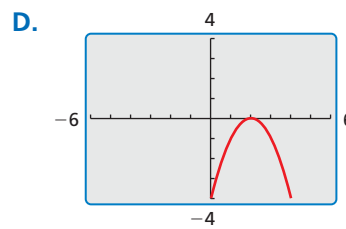
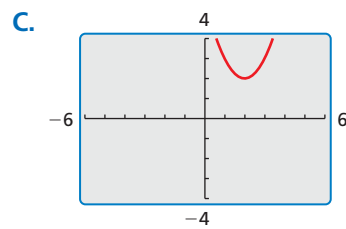
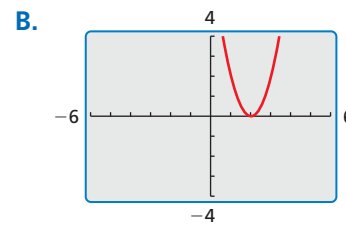
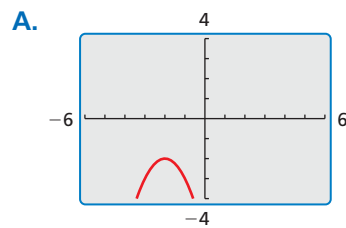

LOOKING FOR STRUCTURE

To be proficient in math, you need to look closely to discern a pattern or structure.

Communicate Your Answer

- How do the constants a , h , and k affect the graph of the quadratic function $g(x) = a(x - h)^2 + k$?
- Write the equation of the quadratic function whose graph is shown at the right. Explain your reasoning. Then use a graphing calculator to verify that your equation is correct.

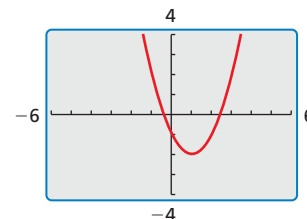

2.1 Lesson

Core Vocabulary

quadratic function, p. 48
 parabola, p. 48
 vertex of a parabola, p. 50
 vertex form, p. 50

Previous
 transformations

What You Will Learn

- ▶ Describe transformations of quadratic functions.
- ▶ Write transformations of quadratic functions.

Describing Transformations of Quadratic Functions

A **quadratic function** is a function that can be written in the form $f(x) = a(x - h)^2 + k$, where $a \neq 0$. The U-shaped graph of a quadratic function is called a **parabola**.

In Section 1.1, you graphed quadratic functions using tables of values. You can also graph quadratic functions by applying transformations to the graph of the parent function $f(x) = x^2$.

Core Concept

Horizontal Translations

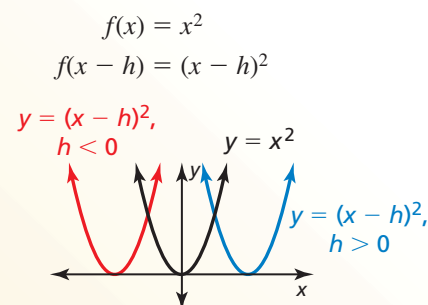

- shifts left when $h < 0$
- shifts right when $h > 0$

Vertical Translations

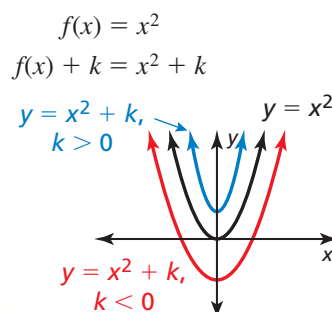

- shifts down when $k < 0$
- shifts up when $k > 0$

EXAMPLE 1 Translations of a Quadratic Function

Describe the transformation of $f(x) = x^2$ represented by $g(x) = (x + 4)^2 - 1$. Then graph each function.

SOLUTION

Notice that the function is of the form $g(x) = (x - h)^2 + k$. Rewrite the function to identify h and k .

$$g(x) = (x - (-4))^2 + (-1)$$

↑ ↑
 h k

- ▶ Because $h = -4$ and $k = -1$, the graph of g is a translation 4 units left and 1 unit down of the graph of f .

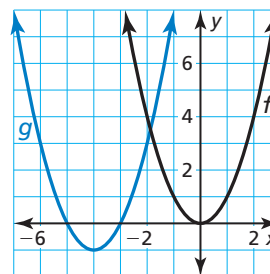

Monitoring Progress Help in English and Spanish at BigIdeasMath.com

Describe the transformation of $f(x) = x^2$ represented by g . Then graph each function.

1. $g(x) = (x - 3)^2$
2. $g(x) = (x - 2)^2 - 2$
3. $g(x) = (x + 5)^2 + 1$

Core Concept

Reflections in the x-Axis

$$f(x) = x^2$$

$$-f(x) = -(x^2) = -x^2$$

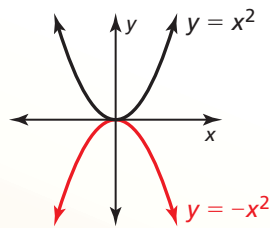

flips over the x -axis

Reflections in the y-Axis

$$f(x) = x^2$$

$$f(-x) = (-x)^2 = x^2$$

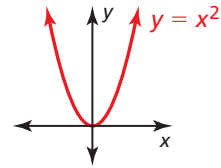

$y = x^2$ is its own reflection in the y -axis.

Horizontal Stretches and Shrinks

$$f(x) = x^2$$

$$f(ax) = (ax)^2$$

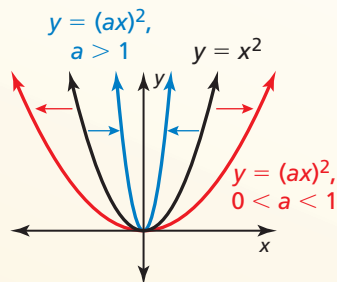

- horizontal stretch (away from y -axis) when $0 < a < 1$
- horizontal shrink (toward y -axis) when $a > 1$

Vertical Stretches and Shrinks

$$f(x) = x^2$$

$$a \cdot f(x) = ax^2$$

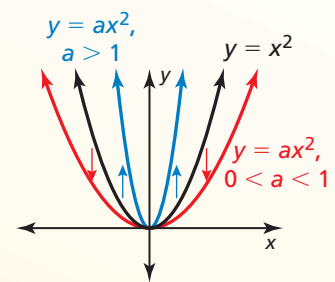

- vertical stretch (away from x -axis) when $a > 1$
- vertical shrink (toward x -axis) when $0 < a < 1$

LOOKING FOR STRUCTURE

In Example 2b, notice that $g(x) = 4x^2 + 1$. So, you can also describe the graph of g as a vertical stretch by a factor of 4 followed by a translation 1 unit up of the graph of f .

EXAMPLE 2

Transformations of Quadratic Functions

Describe the transformation of $f(x) = x^2$ represented by g . Then graph each function.

a. $g(x) = -\frac{1}{2}x^2$

b. $g(x) = (2x)^2 + 1$

SOLUTION

a. Notice that the function is of the form $g(x) = -ax^2$, where $a = \frac{1}{2}$.

- So, the graph of g is a reflection in the x -axis and a vertical shrink by a factor of $\frac{1}{2}$ of the graph of f .

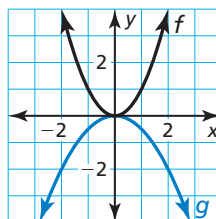

b. Notice that the function is of the form $g(x) = (ax)^2 + k$, where $a = 2$ and $k = 1$.

- So, the graph of g is a horizontal shrink by a factor of $\frac{1}{2}$ followed by a translation 1 unit up of the graph of f .

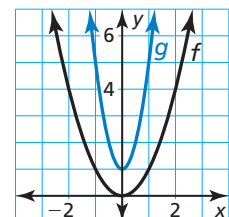

Describe the transformation of $f(x) = x^2$ represented by g . Then graph each function.

4. $g(x) = \left(\frac{1}{3}x\right)^2$

5. $g(x) = 3(x - 1)^2$

6. $g(x) = -(x + 3)^2 + 2$

Writing Transformations of Quadratic Functions

The lowest point on a parabola that opens up or the highest point on a parabola that opens down is the **vertex**. The **vertex form** of a quadratic function is $f(x) = a(x - h)^2 + k$, where $a \neq 0$ and the vertex is (h, k) .

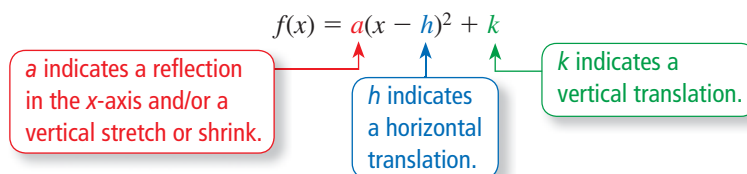

EXAMPLE 3 Writing a Transformed Quadratic Function

Let the graph of g be a vertical stretch by a factor of 2 and a reflection in the x -axis, followed by a translation 3 units down of the graph of $f(x) = x^2$. Write a rule for g and identify the vertex.

SOLUTION

Method 1 Identify how the transformations affect the constants in vertex form.

$$\left. \begin{array}{l} \text{reflection in } x\text{-axis} \\ \text{vertical stretch by } 2 \\ \text{translation 3 units down} \end{array} \right\} \begin{array}{l} a = -2 \\ k = -3 \end{array}$$

Write the transformed function.

$$\begin{aligned} g(x) &= a(x - h)^2 + k && \text{Vertex form of a quadratic function} \\ &= -2(x - 0)^2 + (-3) && \text{Substitute } -2 \text{ for } a, 0 \text{ for } h, \text{ and } -3 \text{ for } k. \\ &= -2x^2 - 3 && \text{Simplify.} \end{aligned}$$

► The transformed function is $g(x) = -2x^2 - 3$. The vertex is $(0, -3)$.

Method 2 Begin with the parent function and apply the transformations one at a time in the stated order.

First write a function h that represents the reflection and vertical stretch of f .

$$\begin{aligned} h(x) &= -2 \cdot f(x) && \text{Multiply the output by } -2. \\ &= -2x^2 && \text{Substitute } x^2 \text{ for } f(x). \end{aligned}$$

Then write a function g that represents the translation of h .

$$\begin{aligned} g(x) &= h(x) - 3 && \text{Subtract 3 from the output.} \\ &= -2x^2 - 3 && \text{Substitute } -2x^2 \text{ for } h(x). \end{aligned}$$

► The transformed function is $g(x) = -2x^2 - 3$. The vertex is $(0, -3)$.

Check

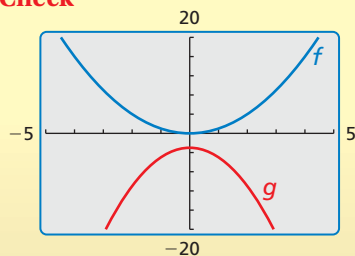

REMEMBER

To multiply two binomials, use the FOIL Method.

$$(x + 1)(x + 2) = x^2 + 2x + x + 2$$

First Inner
Outer Last

EXAMPLE 4 Writing a Transformed Quadratic Function

Let the graph of g be a translation 3 units right and 2 units up, followed by a reflection in the y -axis of the graph of $f(x) = x^2 - 5x$. Write a rule for g .

SOLUTION

Step 1 First write a function h that represents the translation of f .

$$\begin{aligned} h(x) &= f(x - 3) + 2 && \text{Subtract 3 from the input. Add 2 to the output.} \\ &= (x - 3)^2 - 5(x - 3) + 2 && \text{Replace } x \text{ with } x - 3 \text{ in } f(x). \\ &= x^2 - 11x + 26 && \text{Simplify.} \end{aligned}$$

Step 2 Then write a function g that represents the reflection of h .

$$\begin{aligned} g(x) &= h(-x) && \text{Multiply the input by } -1. \\ &= (-x)^2 - 11(-x) + 26 && \text{Replace } x \text{ with } -x \text{ in } h(x). \\ &= x^2 + 11x + 26 && \text{Simplify.} \end{aligned}$$



EXAMPLE 5 Modeling with Mathematics

The height h (in feet) of water spraying from a fire hose can be modeled by $h(x) = -0.03x^2 + x + 25$, where x is the horizontal distance (in feet) from the fire truck. The crew raises the ladder so that the water hits the ground 10 feet farther from the fire truck. Write a function that models the new path of the water.

SOLUTION

- 1. Understand the Problem** You are given a function that represents the path of water spraying from a fire hose. You are asked to write a function that represents the path of the water after the crew raises the ladder.
- 2. Make a Plan** Analyze the graph of the function to determine the translation of the ladder that causes water to travel 10 feet farther. Then write the function.
- 3. Solve the Problem** Use a graphing calculator to graph the original function.

Because $h(50) = 0$, the water originally hits the ground 50 feet from the fire truck. The range of the function in this context does not include negative values. However, by observing that $h(60) = -23$, you can determine that a translation 23 units (feet) up causes the water to travel 10 feet farther from the fire truck.

$$\begin{aligned} g(x) &= h(x) + 23 && \text{Add 23 to the output.} \\ &= -0.03x^2 + x + 48 && \text{Substitute for } h(x) \text{ and simplify.} \end{aligned}$$

▶ The new path of the water can be modeled by $g(x) = -0.03x^2 + x + 48$.

- 4. Look Back** To check that your solution is correct, verify that $g(60) = 0$.

$$g(60) = -0.03(60)^2 + 60 + 48 = -108 + 60 + 48 = 0 \quad \checkmark$$

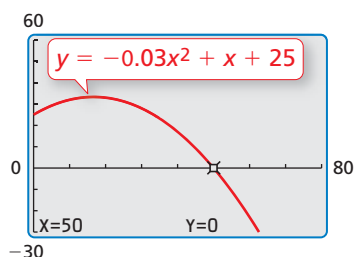

Monitoring Progress Help in English and Spanish at BigIdeasMath.com

7. Let the graph of g be a vertical shrink by a factor of $\frac{1}{2}$ followed by a translation 2 units up of the graph of $f(x) = x^2$. Write a rule for g and identify the vertex.
8. Let the graph of g be a translation 4 units left followed by a horizontal shrink by a factor of $\frac{1}{3}$ of the graph of $f(x) = x^2 + x$. Write a rule for g .
9. **WHAT IF?** In Example 5, the water hits the ground 10 feet closer to the fire truck after lowering the ladder. Write a function that models the new path of the water.

2.1 Exercises

Vocabulary and Core Concept Check

- COMPLETE THE SENTENCE** The graph of a quadratic function is called a(n) _____.
- VOCABULARY** Identify the vertex of the parabola given by $f(x) = (x + 2)^2 - 4$.

Monitoring Progress and Modeling with Mathematics

In Exercises 3–12, describe the transformation of $f(x) = x^2$ represented by g . Then graph each function. (See Example 1.)

- | | |
|----------------------------|-----------------------------|
| 3. $g(x) = x^2 - 3$ | 4. $g(x) = x^2 + 1$ |
| 5. $g(x) = (x + 2)^2$ | 6. $g(x) = (x - 4)^2$ |
| 7. $g(x) = (x - 1)^2$ | 8. $g(x) = (x + 3)^2$ |
| 9. $g(x) = (x + 6)^2 - 2$ | 10. $g(x) = (x - 9)^2 + 5$ |
| 11. $g(x) = (x - 7)^2 + 1$ | 12. $g(x) = (x + 10)^2 - 3$ |

ANALYZING RELATIONSHIPS

In Exercises 13–16, match the function with the correct transformation of the graph of f . Explain your reasoning.

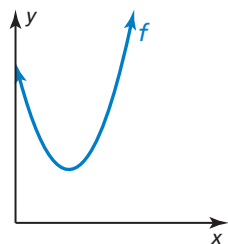

- | | |
|------------------------|------------------------|
| 13. $y = f(x - 1)$ | 14. $y = f(x) + 1$ |
| 15. $y = f(x - 1) + 1$ | 16. $y = f(x + 1) - 1$ |

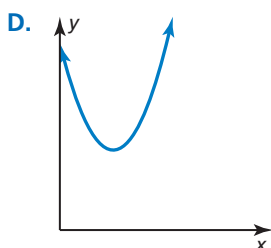
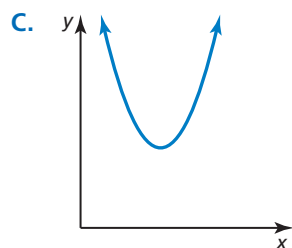
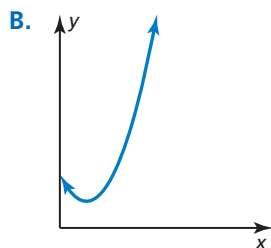
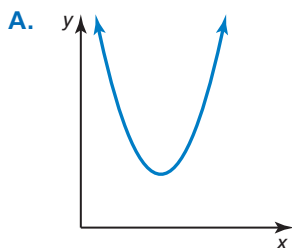

In Exercises 17–24, describe the transformation of $f(x) = x^2$ represented by g . Then graph each function. (See Example 2.)

- | | |
|---------------------------------|-----------------------------------|
| 17. $g(x) = -x^2$ | 18. $g(x) = (-x)^2$ |
| 19. $g(x) = 3x^2$ | 20. $g(x) = \frac{1}{3}x^2$ |
| 21. $g(x) = (2x)^2$ | 22. $g(x) = -(2x)^2$ |
| 23. $g(x) = \frac{1}{5}x^2 - 4$ | 24. $g(x) = \frac{1}{2}(x - 1)^2$ |

ERROR ANALYSIS In Exercises 25 and 26, describe and correct the error in analyzing the graph of $f(x) = -6x^2 + 4$.

25. The graph is a reflection in the y -axis and a vertical stretch by a factor of 6, followed by a translation 4 units up of the graph of the parent quadratic function.

26. The graph is a translation 4 units down, followed by a vertical stretch by a factor of 6 and a reflection in the x -axis of the graph of the parent quadratic function.

USING STRUCTURE In Exercises 27–30, describe the transformation of the graph of the parent quadratic function. Then identify the vertex.

- $f(x) = 3(x + 2)^2 + 1$
- $f(x) = -4(x + 1)^2 - 5$
- $f(x) = -2x^2 + 5$
- $f(x) = \frac{1}{2}(x - 1)^2$

In Exercises 31–34, write a rule for g described by the transformations of the graph of f . Then identify the vertex. (See Examples 3 and 4.)

31. $f(x) = x^2$; vertical stretch by a factor of 4 and a reflection in the x -axis, followed by a translation 2 units up
32. $f(x) = x^2$; vertical shrink by a factor of $\frac{1}{3}$ and a reflection in the y -axis, followed by a translation 3 units right
33. $f(x) = 8x^2 - 6$; horizontal stretch by a factor of 2 and a translation 2 units up, followed by a reflection in the y -axis
34. $f(x) = (x + 6)^2 + 3$; horizontal shrink by a factor of $\frac{1}{2}$ and a translation 1 unit down, followed by a reflection in the x -axis

USING TOOLS In Exercises 35–40, match the function with its graph. Explain your reasoning.

35. $g(x) = 2(x - 1)^2 - 2$ 36. $g(x) = \frac{1}{2}(x + 1)^2 - 2$
37. $g(x) = -2(x - 1)^2 + 2$
38. $g(x) = 2(x + 1)^2 + 2$ 39. $g(x) = -2(x + 1)^2 - 2$
40. $g(x) = 2(x - 1)^2 + 2$

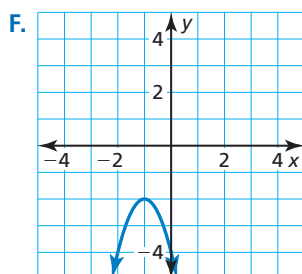
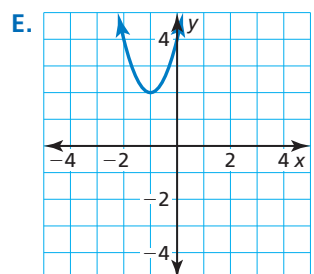
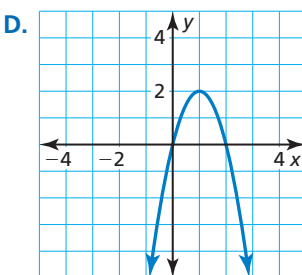
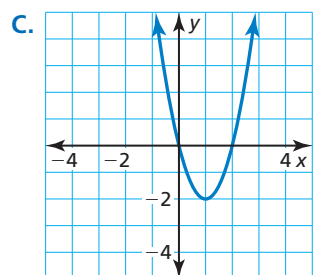
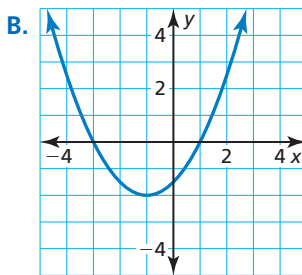
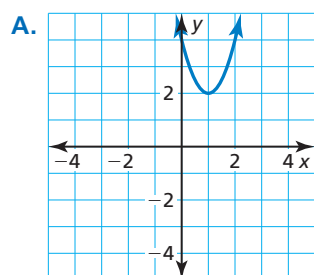

JUSTIFYING STEPS In Exercises 41 and 42, justify each step in writing a function g based on the transformations of $f(x) = 2x^2 + 6x$.

41. translation 6 units down followed by a reflection in the x -axis
- $$h(x) = f(x) - 6$$
- $$= 2x^2 + 6x - 6$$
- $$g(x) = -h(x)$$
- $$= -(2x^2 + 6x - 6)$$
- $$= -2x^2 - 6x + 6$$
42. reflection in the y -axis followed by a translation 4 units right
- $$h(x) = f(-x)$$
- $$= 2(-x)^2 + 6(-x)$$
- $$= 2x^2 - 6x$$
- $$g(x) = h(x - 4)$$
- $$= 2(x - 4)^2 - 6(x - 4)$$
- $$= 2x^2 - 22x + 56$$

43. **MODELING WITH MATHEMATICS** The function $h(x) = -0.03(x - 14)^2 + 6$ models the jump of a red kangaroo, where x is the horizontal distance traveled (in feet) and $h(x)$ is the height (in feet). When the kangaroo jumps from a higher location, it lands 5 feet farther away. Write a function that models the second jump. (See Example 5.)



44. **MODELING WITH MATHEMATICS** The function $f(t) = -16t^2 + 10$ models the height (in feet) of an object t seconds after it is dropped from a height of 10 feet on Earth. The same object dropped from the same height on the moon is modeled by $g(t) = -\frac{8}{3}t^2 + 10$. Describe the transformation of the graph of f to obtain g . From what height must the object be dropped on the moon so it hits the ground at the same time as on Earth?

45. MODELING WITH MATHEMATICS Flying fish use their pectoral fins like airplane wings to glide through the air.

- Write an equation of the form $y = a(x - h)^2 + k$ with vertex $(33, 5)$ that models the flight path, assuming the fish leaves the water at $(0, 0)$.
- What are the domain and range of the function? What do they represent in this situation?
- Does the value of a change when the flight path has vertex $(30, 4)$? Justify your answer.



47. COMPARING METHODS Let the graph of g be a translation 3 units up and 1 unit right followed by a vertical stretch by a factor of 2 of the graph of $f(x) = x^2$.

- Identify the values of a , h , and k and use vertex form to write the transformed function.
- Use function notation to write the transformed function. Compare this function with your function in part (a).
- Suppose the vertical stretch was performed first, followed by the translations. Repeat parts (a) and (b).
- Which method do you prefer when writing a transformed function? Explain.

48. THOUGHT PROVOKING A jump on a pogo stick with a conventional spring can be modeled by $f(x) = -0.5(x - 6)^2 + 18$, where x is the horizontal distance (in inches) and $f(x)$ is the vertical distance (in inches). Write at least one transformation of the function and provide a possible reason for your transformation.

46. HOW DO YOU SEE IT? Describe the graph of g as a transformation of the graph of $f(x) = x^2$.

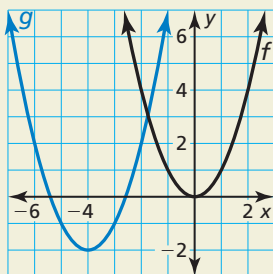

49. MATHEMATICAL CONNECTIONS The area of a circle depends on the radius, as shown in the graph. A circular earring with a radius of r millimeters has a circular hole with a radius of $\frac{3r}{4}$ millimeters. Describe a transformation of the graph below that models the area of the blue portion of the earring.

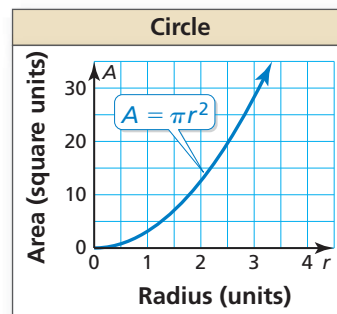

Maintaining Mathematical Proficiency

Reviewing what you learned in previous grades and lessons

A line of symmetry for the figure is shown in red. Find the coordinates of point A .

(Skills Review Handbook)

50.

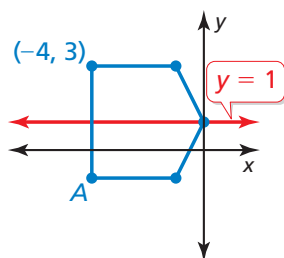

51.

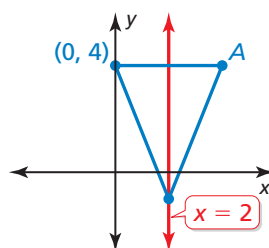

52.

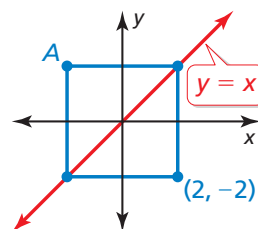

2.2 Characteristics of Quadratic Functions

Essential Question What type of symmetry does the graph of $f(x) = a(x - h)^2 + k$ have and how can you describe this symmetry?

EXPLORATION 1 Parabolas and Symmetry

Work with a partner.

- a. Complete the table. Then use the values in the table to sketch the graph of the function

$$f(x) = \frac{1}{2}x^2 - 2x - 2$$

on graph paper.

x	-2	-1	0	1	2
f(x)					

x	3	4	5	6
f(x)				

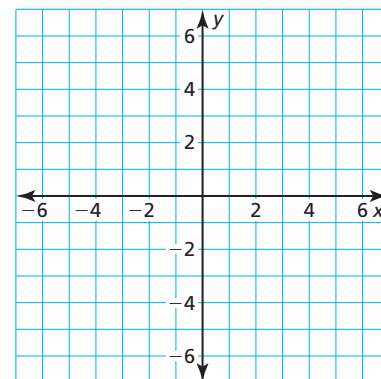

- b. Use the results in part (a) to identify the vertex of the parabola.
- c. Find a vertical line on your graph paper so that when you fold the paper, the left portion of the graph coincides with the right portion of the graph. What is the equation of this line? How does it relate to the vertex?
- d. Show that the vertex form

$$f(x) = \frac{1}{2}(x - 2)^2 - 4$$

is equivalent to the function given in part (a).

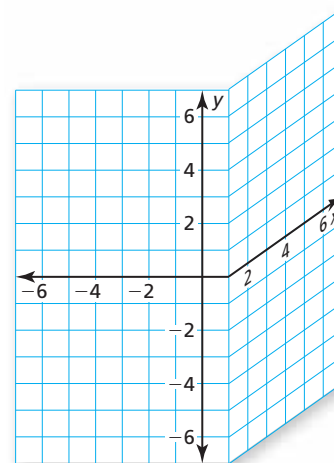

EXPLORATION 2 Parabolas and Symmetry

Work with a partner. Repeat Exploration 1 for the function given by

$$f(x) = -\frac{1}{3}x^2 + 2x + 3 = -\frac{1}{3}(x - 3)^2 + 6.$$

Communicate Your Answer

3. What type of symmetry does the graph of $f(x) = a(x - h)^2 + k$ have and how can you describe this symmetry?
4. Describe the symmetry of each graph. Then use a graphing calculator to verify your answer.
- a. $f(x) = -(x - 1)^2 + 4$ b. $f(x) = (x + 1)^2 - 2$ c. $f(x) = 2(x - 3)^2 + 1$
 d. $f(x) = \frac{1}{2}(x + 2)^2$ e. $f(x) = -2x^2 + 3$ f. $f(x) = 3(x - 5)^2 + 2$

ATTENDING TO PRECISION

To be proficient in math, you need to use clear definitions in your reasoning and discussions with others.



2.2 Lesson

Core Vocabulary

axis of symmetry, p. 56
 standard form, p. 56
 minimum value, p. 58
 maximum value, p. 58
 intercept form, p. 59

Previous
 x-intercept

What You Will Learn

- ▶ Explore properties of parabolas.
- ▶ Find maximum and minimum values of quadratic functions.
- ▶ Graph quadratic functions using x-intercepts.
- ▶ Solve real-life problems.

Exploring Properties of Parabolas

An **axis of symmetry** is a line that divides a parabola into mirror images and passes through the vertex. Because the vertex of $f(x) = a(x - h)^2 + k$ is (h, k) , the axis of symmetry is the vertical line $x = h$.

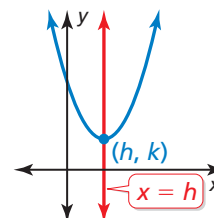

Previously, you used transformations to graph quadratic functions in vertex form. You can also use the axis of symmetry and the vertex to graph quadratic functions written in vertex form.

EXAMPLE 1 Using Symmetry to Graph Quadratic Functions

Graph $f(x) = -2(x + 3)^2 + 4$. Label the vertex and axis of symmetry.

SOLUTION

Step 1 Identify the constants $a = -2$, $h = -3$, and $k = 4$.

Step 2 Plot the vertex $(h, k) = (-3, 4)$ and draw the axis of symmetry $x = -3$.

Step 3 Evaluate the function for two values of x .

$$x = -2: f(-2) = -2(-2 + 3)^2 + 4 = 2$$

$$x = -1: f(-1) = -2(-1 + 3)^2 + 4 = -4$$

Plot the points $(-2, 2)$, $(-1, -4)$, and their reflections in the axis of symmetry.

Step 4 Draw a parabola through the plotted points.

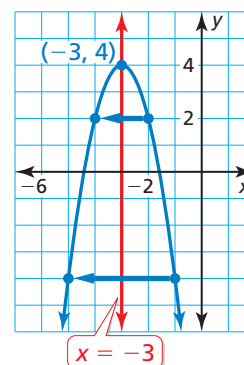

Quadratic functions can also be written in **standard form**, $f(x) = ax^2 + bx + c$, where $a \neq 0$. You can derive standard form by expanding vertex form.

$$f(x) = a(x - h)^2 + k$$

Vertex form

$$f(x) = a(x^2 - 2hx + h^2) + k$$

Expand $(x - h)^2$.

$$f(x) = ax^2 - 2ahx + ah^2 + k$$

Distributive Property

$$f(x) = ax^2 + (-2ah)x + (ah^2 + k)$$

Group like terms.

$$f(x) = ax^2 + bx + c$$

Let $b = -2ah$ and let $c = ah^2 + k$.

This allows you to make the following observations.

$a = a$: So, a has the same meaning in vertex form and standard form.

$b = -2ah$: Solve for h to obtain $h = -\frac{b}{2a}$. So, the axis of symmetry is $x = -\frac{b}{2a}$.

$c = ah^2 + k$: In vertex form $f(x) = a(x - h)^2 + k$, notice that $f(0) = ah^2 + k$. So, c is the y-intercept.

Core Concept

Properties of the Graph of $f(x) = ax^2 + bx + c$

$$y = ax^2 + bx + c, a > 0$$

$$y = ax^2 + bx + c, a < 0$$

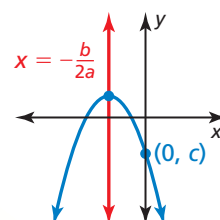
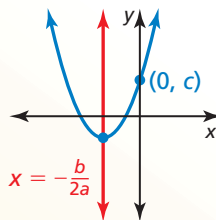

- The parabola opens up when $a > 0$ and opens down when $a < 0$.
- The graph is narrower than the graph of $f(x) = x^2$ when $|a| > 1$ and wider when $|a| < 1$.
- The axis of symmetry is $x = -\frac{b}{2a}$ and the vertex is $\left(-\frac{b}{2a}, f\left(-\frac{b}{2a}\right)\right)$.
- The y-intercept is c . So, the point $(0, c)$ is on the parabola.

EXAMPLE 2

Graphing a Quadratic Function in Standard Form

Graph $f(x) = 3x^2 - 6x + 1$. Label the vertex and axis of symmetry.

COMMON ERROR

Be sure to include the negative sign when writing the expression for the x-coordinate of the vertex.

SOLUTION

Step 1 Identify the coefficients $a = 3$, $b = -6$, and $c = 1$. Because $a > 0$, the parabola opens up.

Step 2 Find the vertex. First calculate the x-coordinate.

$$x = -\frac{b}{2a} = -\frac{-6}{2(3)} = 1$$

Then find the y-coordinate of the vertex.

$$f(1) = 3(1)^2 - 6(1) + 1 = -2$$

So, the vertex is $(1, -2)$. Plot this point.

Step 3 Draw the axis of symmetry $x = 1$.

Step 4 Identify the y-intercept c , which is 1. Plot the point $(0, 1)$ and its reflection in the axis of symmetry, $(2, 1)$.

Step 5 Evaluate the function for another value of x , such as $x = 3$.

$$f(3) = 3(3)^2 - 6(3) + 1 = 10$$

Plot the point $(3, 10)$ and its reflection in the axis of symmetry, $(-1, 10)$.

Step 6 Draw a parabola through the plotted points.

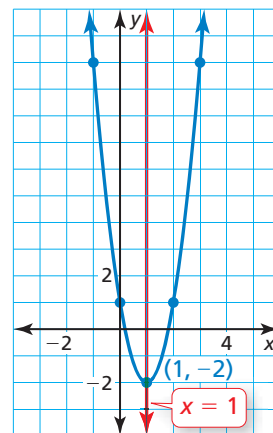

Monitoring Progress



Help in English and Spanish at BigIdeasMath.com

Graph the function. Label the vertex and axis of symmetry.

1. $f(x) = -3(x + 1)^2$

2. $g(x) = 2(x - 2)^2 + 5$

3. $h(x) = x^2 + 2x - 1$

4. $p(x) = -2x^2 - 8x + 1$

Finding Maximum and Minimum Values

Because the vertex is the highest or lowest point on a parabola, its y -coordinate is the *maximum value* or *minimum value* of the function. The vertex lies on the axis of symmetry, so the function is *increasing* on one side of the axis of symmetry and *decreasing* on the other side.

Core Concept

Minimum and Maximum Values

For the quadratic function $f(x) = ax^2 + bx + c$, the y -coordinate of the vertex is the **minimum value** of the function when $a > 0$ and the **maximum value** when $a < 0$.

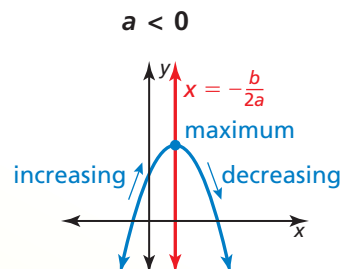
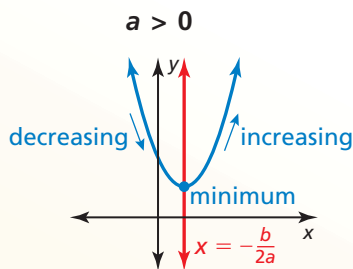

STUDY TIP

When a function f is written in vertex form, you can use $h = -\frac{b}{2a}$ and $k = f\left(-\frac{b}{2a}\right)$ to state the properties shown.

- | | |
|--|--|
| <ul style="list-style-type: none"> • Minimum value: $f\left(-\frac{b}{2a}\right)$ • Domain: All real numbers • Range: $y \geq f\left(-\frac{b}{2a}\right)$ • Decreasing to the left of $x = -\frac{b}{2a}$ • Increasing to the right of $x = -\frac{b}{2a}$ | <ul style="list-style-type: none"> • Maximum value: $f\left(-\frac{b}{2a}\right)$ • Domain: All real numbers • Range: $y \leq f\left(-\frac{b}{2a}\right)$ • Increasing to the left of $x = -\frac{b}{2a}$ • Decreasing to the right of $x = -\frac{b}{2a}$ |
|--|--|

EXAMPLE 3 Finding a Minimum or a Maximum Value

Find the minimum value or maximum value of $f(x) = \frac{1}{2}x^2 - 2x - 1$. Describe the domain and range of the function, and where the function is increasing and decreasing.

SOLUTION

Identify the coefficients $a = \frac{1}{2}$, $b = -2$, and $c = -1$. Because $a > 0$, the parabola opens up and the function has a minimum value. To find the minimum value, calculate the coordinates of the vertex.

$$x = -\frac{b}{2a} = -\frac{-2}{2\left(\frac{1}{2}\right)} = 2 \quad \Rightarrow \quad f(2) = \frac{1}{2}(2)^2 - 2(2) - 1 = -3$$

- ▶ The minimum value is -3 . So, the domain is all real numbers and the range is $y \geq -3$. The function is decreasing to the left of $x = 2$ and increasing to the right of $x = 2$.

Check

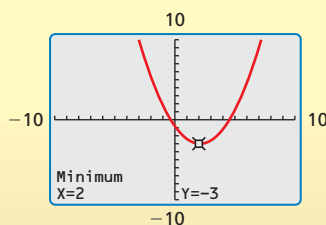

Monitoring Progress Help in English and Spanish at BigIdeasMath.com

5. Find the minimum value or maximum value of (a) $f(x) = 4x^2 + 16x - 3$ and (b) $h(x) = -x^2 + 5x + 9$. Describe the domain and range of each function, and where each function is increasing and decreasing.

Graphing Quadratic Functions Using x-Intercepts

When the graph of a quadratic function has at least one x -intercept, the function can be written in **intercept form**, $f(x) = a(x - p)(x - q)$, where $a \neq 0$.

REMEMBER

An x -intercept of a graph is the x -coordinate of a point where the graph intersects the x -axis. It occurs where $f(x) = 0$.

Core Concept

Properties of the Graph of $f(x) = a(x - p)(x - q)$

- Because $f(p) = 0$ and $f(q) = 0$, p and q are the x -intercepts of the graph of the function.
- The axis of symmetry is halfway between $(p, 0)$ and $(q, 0)$. So, the axis of symmetry is $x = \frac{p + q}{2}$.
- The parabola opens up when $a > 0$ and opens down when $a < 0$.

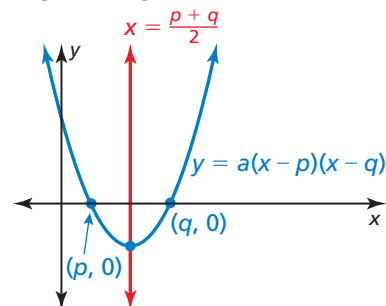

COMMON ERROR

Remember that the x -intercepts of the graph of $f(x) = a(x - p)(x - q)$ are p and q , not $-p$ and $-q$.

EXAMPLE 4

Graphing a Quadratic Function in Intercept Form

Graph $f(x) = -2(x + 3)(x - 1)$. Label the x -intercepts, vertex, and axis of symmetry.

SOLUTION

Step 1 Identify the x -intercepts. The x -intercepts are $p = -3$ and $q = 1$, so the parabola passes through the points $(-3, 0)$ and $(1, 0)$.

Step 2 Find the coordinates of the vertex.

$$x = \frac{p + q}{2} = \frac{-3 + 1}{2} = -1$$

$$f(-1) = -2(-1 + 3)(-1 - 1) = 8$$

So, the axis of symmetry is $x = -1$ and the vertex is $(-1, 8)$.

Step 3 Draw a parabola through the vertex and the points where the x -intercepts occur.

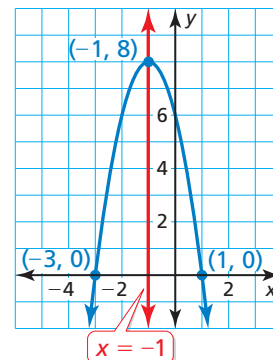

Check You can check your answer by generating a table of values for f on a graphing calculator.

X	Y1
-4	-10
-3	0
-2	6
-1	8
0	6
1	0
2	-10

X=-1

x -intercept

x -intercept

The values show symmetry about $x = -1$. So, the vertex is $(-1, 8)$.

Monitoring Progress



Help in English and Spanish at BigIdeasMath.com

Graph the function. Label the x -intercepts, vertex, and axis of symmetry.

6. $f(x) = -(x + 1)(x + 5)$

7. $g(x) = \frac{1}{4}(x - 6)(x - 2)$

Solving Real-Life Problems

EXAMPLE 5 Modeling with Mathematics

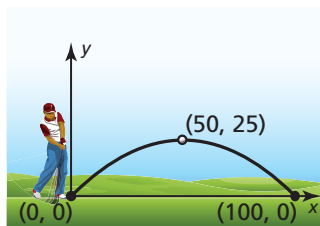

The parabola shows the path of your first golf shot, where x is the horizontal distance (in yards) and y is the corresponding height (in yards). The path of your second shot can be modeled by the function $f(x) = -0.02x(x - 80)$. Which shot travels farther before hitting the ground? Which travels higher?

SOLUTION

- Understand the Problem** You are given a graph and a function that represent the paths of two golf shots. You are asked to determine which shot travels farther before hitting the ground and which shot travels higher.
- Make a Plan** Determine how far each shot travels by interpreting the x -intercepts. Determine how high each shot travels by finding the maximum value of each function. Then compare the values.
- Solve the Problem**

First shot: The graph shows that the x -intercepts are 0 and 100. So, the ball travels 100 yards before hitting the ground.

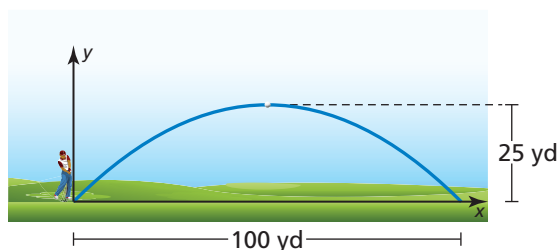

Because the axis of symmetry is halfway between $(0, 0)$ and $(100, 0)$, the axis of symmetry is $x = \frac{0 + 100}{2} = 50$. So, the vertex is $(50, 25)$ and the maximum height is 25 yards.

Second shot: By rewriting the function in intercept form as $f(x) = -0.02(x - 0)(x - 80)$, you can see that $p = 0$ and $q = 80$. So, the ball travels 80 yards before hitting the ground.

To find the maximum height, find the coordinates of the vertex.

$$x = \frac{p + q}{2} = \frac{0 + 80}{2} = 40$$

$$f(40) = -0.02(40)(40 - 80) = 32$$

The maximum height of the second shot is 32 yards.

- ▶ Because 100 yards $>$ 80 yards, the first shot travels farther.
Because 32 yards $>$ 25 yards, the second shot travels higher.

- Look Back** To check that the second shot travels higher, graph the function representing the path of the second shot and the line $y = 25$, which represents the maximum height of the first shot.

The graph rises above $y = 25$, so the second shot travels higher. ✓

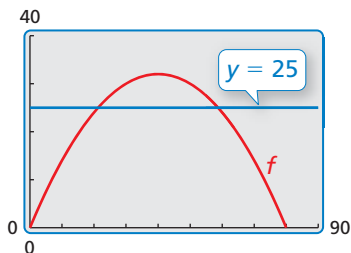

Monitoring Progress Help in English and Spanish at BigIdeasMath.com

- WHAT IF?** The graph of your third shot is a parabola through the origin that reaches a maximum height of 28 yards when $x = 45$. Compare the distance it travels before it hits the ground with the distances of the first two shots.

2.2 Exercises

Vocabulary and Core Concept Check

- WRITING** Explain how to determine whether a quadratic function will have a minimum value or a maximum value.
- WHICH ONE DOESN'T BELONG?** The graph of which function does *not* belong with the other three? Explain.

$$f(x) = 3x^2 + 6x - 24$$

$$f(x) = 3x^2 + 24x - 6$$

$$f(x) = 3(x - 2)(x + 4)$$

$$f(x) = 3(x + 1)^2 - 27$$

Monitoring Progress and Modeling with Mathematics

In Exercises 3–14, graph the function. Label the vertex and axis of symmetry. (See Example 1.)

- | | |
|-------------------------------------|------------------------------------|
| 3. $f(x) = (x - 3)^2$ | 4. $h(x) = (x + 4)^2$ |
| 5. $g(x) = (x + 3)^2 + 5$ | 6. $y = (x - 7)^2 - 1$ |
| 7. $y = -4(x - 2)^2 + 4$ | 8. $g(x) = 2(x + 1)^2 - 3$ |
| 9. $f(x) = -2(x - 1)^2 - 5$ | 10. $h(x) = 4(x + 4)^2 + 6$ |
| 11. $y = -\frac{1}{4}(x + 2)^2 + 1$ | 12. $y = \frac{1}{2}(x - 3)^2 + 2$ |
| 13. $f(x) = 0.4(x - 1)^2$ | 14. $g(x) = 0.75x^2 - 5$ |

ANALYZING RELATIONSHIPS In Exercises 15–18, use the axis of symmetry to match the equation with its graph.

- | | |
|------------------------------------|-------------------------|
| 15. $y = 2(x - 3)^2 + 1$ | 16. $y = (x + 4)^2 - 2$ |
| 17. $y = \frac{1}{2}(x + 1)^2 + 3$ | 18. $y = (x - 2)^2 - 1$ |

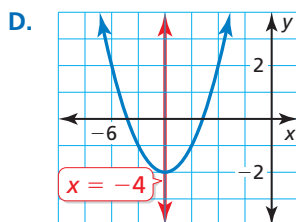
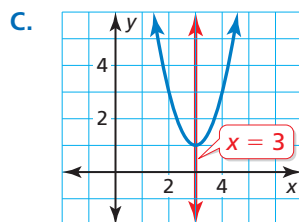
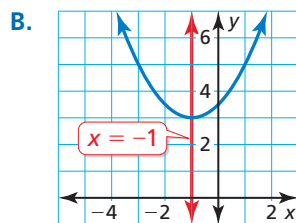
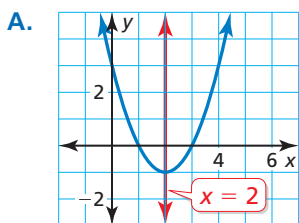

REASONING In Exercises 19 and 20, use the axis of symmetry to plot the reflection of each point and complete the parabola.

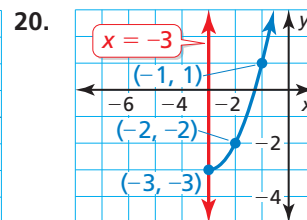
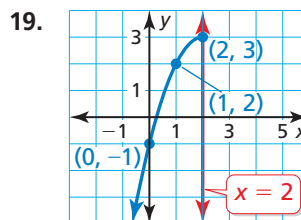



In Exercises 21–30, graph the function. Label the vertex and axis of symmetry. (See Example 2.)

- | | |
|-----------------------------------|------------------------------------|
| 21. $y = x^2 + 2x + 1$ | 22. $y = 3x^2 - 6x + 4$ |
| 23. $y = -4x^2 + 8x + 2$ | 24. $f(x) = -x^2 - 6x + 3$ |
| 25. $g(x) = -x^2 - 1$ | 26. $f(x) = 6x^2 - 5$ |
| 27. $g(x) = -1.5x^2 + 3x + 2$ | |
| 28. $f(x) = 0.5x^2 + x - 3$ | |
| 29. $y = \frac{3}{2}x^2 - 3x + 6$ | 30. $y = -\frac{5}{2}x^2 - 4x - 1$ |

- WRITING** Two quadratic functions have graphs with vertices (2, 4) and (2, -3). Explain why you can not use the axes of symmetry to distinguish between the two functions.
- WRITING** A quadratic function is increasing to the left of $x = 2$ and decreasing to the right of $x = 2$. Will the vertex be the highest or lowest point on the graph of the parabola? Explain.

ERROR ANALYSIS In Exercises 33 and 34, describe and correct the error in analyzing the graph of $y = 4x^2 + 24x - 7$.

33.  The x -coordinate of the vertex is $x = \frac{b}{2a} = \frac{24}{2(4)} = 3$.

34.  The y -intercept of the graph is the value of c , which is 7.

MODELING WITH MATHEMATICS In Exercises 35 and 36, x is the horizontal distance (in feet) and y is the vertical distance (in feet). Find and interpret the coordinates of the vertex.

35. The path of a basketball thrown at an angle of 45° can be modeled by $y = -0.02x^2 + x + 6$.

36. The path of a shot put released at an angle of 35° can be modeled by $y = -0.01x^2 + 0.7x + 6$.

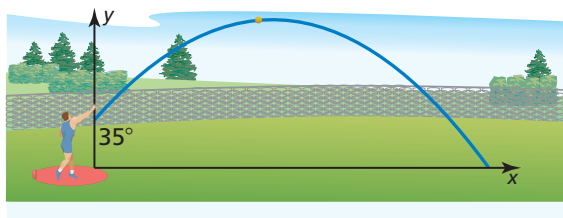

37. **ANALYZING EQUATIONS** The graph of which function has the same axis of symmetry as the graph of $y = x^2 + 2x + 2$?

- (A) $y = 2x^2 + 2x + 2$
- (B) $y = -3x^2 - 6x + 2$
- (C) $y = x^2 - 2x + 2$
- (D) $y = -5x^2 + 10x + 2$

38. **USING STRUCTURE** Which function represents the widest parabola? Explain your reasoning.

- (A) $y = 2(x + 3)^2$
- (B) $y = x^2 - 5$
- (C) $y = 0.5(x - 1)^2 + 1$
- (D) $y = -x^2 + 6$

In Exercises 39–48, find the minimum or maximum value of the function. Describe the domain and range of the function, and where the function is increasing and decreasing. (See Example 3.)

39. $y = 6x^2 - 1$ 40. $y = 9x^2 + 7$

41. $y = -x^2 - 4x - 2$ 42. $g(x) = -3x^2 - 6x + 5$

43. $f(x) = -2x^2 + 8x + 7$

44. $g(x) = 3x^2 + 18x - 5$

45. $h(x) = 2x^2 - 12x$ 46. $h(x) = x^2 - 4x$

47. $y = \frac{1}{4}x^2 - 3x + 2$ 48. $f(x) = \frac{3}{2}x^2 + 6x + 4$

49. **PROBLEM SOLVING** The path of a diver is modeled by the function $f(x) = -9x^2 + 9x + 1$, where $f(x)$ is the height of the diver (in meters) above the water and x is the horizontal distance (in meters) from the end of the diving board.

- a. What is the height of the diving board?
- b. What is the maximum height of the diver?
- c. Describe where the diver is ascending and where the diver is descending.



50. **PROBLEM SOLVING** The engine torque y (in foot-pounds) of one model of car is given by $y = -3.75x^2 + 23.2x + 38.8$, where x is the speed (in thousands of revolutions per minute) of the engine.

- a. Find the engine speed that maximizes torque. What is the maximum torque?
- b. Explain what happens to the engine torque as the speed of the engine increases.

MATHEMATICAL CONNECTIONS In Exercises 51 and 52, write an equation for the area of the figure. Then determine the maximum possible area of the figure.

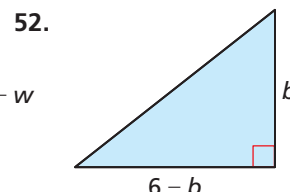
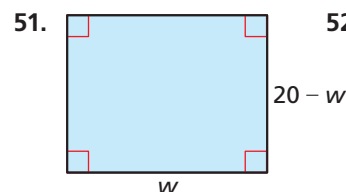

In Exercises 53–60, graph the function. Label the x -intercept(s), vertex, and axis of symmetry.

(See Example 4.)

53. $y = (x + 3)(x - 3)$ 54. $y = (x + 1)(x - 3)$
 55. $y = 3(x + 2)(x + 6)$ 56. $f(x) = 2(x - 5)(x - 1)$
 57. $g(x) = -x(x + 6)$ 58. $y = -4x(x + 7)$
 59. $f(x) = -2(x - 3)^2$ 60. $y = 4(x - 7)^2$

USING TOOLS In Exercises 61–64, identify the x -intercepts of the function and describe where the graph is increasing and decreasing. Use a graphing calculator to verify your answer.

61. $f(x) = \frac{1}{2}(x - 2)(x + 6)$
 62. $y = \frac{3}{4}(x + 1)(x - 3)$
 63. $g(x) = -4(x - 4)(x - 2)$
 64. $h(x) = -5(x + 5)(x + 1)$

65. **MODELING WITH MATHEMATICS** A soccer player kicks a ball downfield. The height of the ball increases until it reaches a maximum height of 8 yards, 20 yards away from the player. A second kick is modeled by $y = x(0.4 - 0.008x)$. Which kick travels farther before hitting the ground? Which kick travels higher? (See Example 5.)



66. **MODELING WITH MATHEMATICS** Although a football field appears to be flat, some are actually shaped like a parabola so that rain runs off to both sides. The cross section of a field can be modeled by $y = -0.000234x(x - 160)$, where x and y are measured in feet. What is the width of the field? What is the maximum height of the surface of the field?

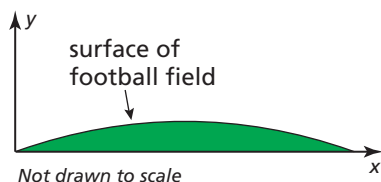

67. **REASONING** The points $(2, 3)$ and $(-4, 2)$ lie on the graph of a quadratic function. Determine whether you can use these points to find the axis of symmetry. If not, explain. If so, write the equation of the axis of symmetry.

68. **OPEN-ENDED** Write two different quadratic functions in intercept form whose graphs have the axis of symmetry $x = 3$.
69. **PROBLEM SOLVING** An online music store sells about 4000 songs each day when it charges \$1 per song. For each \$0.05 increase in price, about 80 fewer songs per day are sold. Use the verbal model and quadratic function to determine how much the store should charge per song to maximize daily revenue.

$$\begin{array}{|c|} \text{Revenue} \\ \text{(dollars)} \end{array} = \begin{array}{|c|} \text{Price} \\ \text{(dollars/song)} \end{array} \cdot \begin{array}{|c|} \text{Sales} \\ \text{(songs)} \end{array}$$

$$R(x) = (1 + 0.05x) \cdot (4000 - 80x)$$

70. **PROBLEM SOLVING** An electronics store sells 70 digital cameras per month at a price of \$320 each. For each \$20 decrease in price, about 5 more cameras per month are sold. Use the verbal model and quadratic function to determine how much the store should charge per camera to maximize monthly revenue.

$$\begin{array}{|c|} \text{Revenue} \\ \text{(dollars)} \end{array} = \begin{array}{|c|} \text{Price} \\ \text{(dollars/camera)} \end{array} \cdot \begin{array}{|c|} \text{Sales} \\ \text{(cameras)} \end{array}$$

$$R(x) = (320 - 20x) \cdot (70 + 5x)$$

71. **DRAWING CONCLUSIONS** Compare the graphs of the three quadratic functions. What do you notice? Rewrite the functions f and g in standard form to justify your answer.

$$f(x) = (x + 3)(x + 1)$$

$$g(x) = (x + 2)^2 - 1$$

$$h(x) = x^2 + 4x + 3$$

72. **USING STRUCTURE** Write the quadratic function $f(x) = x^2 + x - 12$ in intercept form. Graph the function. Label the x -intercepts, y -intercept, vertex, and axis of symmetry.

73. **PROBLEM SOLVING** A woodland jumping mouse hops along a parabolic path given by $y = -0.2x^2 + 1.3x$, where x is the mouse's horizontal distance traveled (in feet) and y is the corresponding height (in feet). Can the mouse jump over a fence that is 3 feet high? Justify your answer.

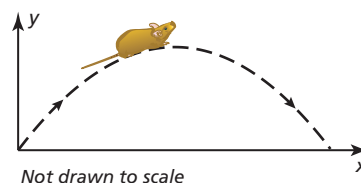

74. **HOW DO YOU SEE IT?** Consider the graph of the function $f(x) = a(x - p)(x - q)$.

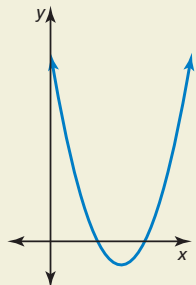

- What does $f\left(\frac{p+q}{2}\right)$ represent in the graph?
- If $a < 0$, how does your answer in part (a) change? Explain.

75. **MODELING WITH MATHEMATICS** The Gateshead Millennium Bridge spans the River Tyne. The arch of the bridge can be modeled by a parabola. The arch reaches a maximum height of 50 meters at a point roughly 63 meters across the river. Graph the curve of the arch. What are the domain and range? What do they represent in this situation?



76. **THOUGHT PROVOKING** You have 100 feet of fencing to enclose a rectangular garden. Draw three possible designs for the garden. Of these, which has the greatest area? Make a conjecture about the dimensions of the rectangular garden with the greatest possible area. Explain your reasoning.

77. **MAKING AN ARGUMENT** The point $(1, 5)$ lies on the graph of a quadratic function with axis of symmetry $x = -1$. Your friend says the vertex could be the point $(0, 5)$. Is your friend correct? Explain.

78. **CRITICAL THINKING** Find the y -intercept in terms of a , p , and q for the quadratic function $f(x) = a(x - p)(x - q)$.

79. **MODELING WITH MATHEMATICS** A kernel of popcorn contains water that expands when the kernel is heated, causing it to pop. The equations below represent the “popping volume” y (in cubic centimeters per gram) of popcorn with moisture content x (as a percent of the popcorn’s weight).

Hot-air popping: $y = -0.761(x - 5.52)(x - 22.6)$

Hot-oil popping: $y = -0.652(x - 5.35)(x - 21.8)$

- For hot-air popping, what moisture content maximizes popping volume? What is the maximum volume?
 - For hot-oil popping, what moisture content maximizes popping volume? What is the maximum volume?
 - Use a graphing calculator to graph both functions in the same coordinate plane. What are the domain and range of each function in this situation? Explain.
80. **ABSTRACT REASONING** A function is written in intercept form with $a > 0$. What happens to the vertex of the graph as a increases? as a approaches 0?

Maintaining Mathematical Proficiency Reviewing what you learned in previous grades and lessons

Solve the equation. Check for extraneous solutions. *(Skills Review Handbook)*

81. $3\sqrt{x} - 6 = 0$

82. $2\sqrt{x-4} - 2 = 2$

83. $\sqrt{5x} + 5 = 0$

84. $\sqrt{3x+8} = \sqrt{x+4}$

Solve the proportion. *(Skills Review Handbook)*

85. $\frac{1}{2} = \frac{x}{4}$

86. $\frac{2}{3} = \frac{x}{9}$

87. $\frac{-1}{4} = \frac{3}{x}$

88. $\frac{5}{2} = \frac{-20}{x}$

2.1–2.2 What Did You Learn?

Core Vocabulary

quadratic function, *p.* 48
parabola, *p.* 48
vertex of a parabola, *p.* 50
vertex form, *p.* 50
axis of symmetry, *p.* 56

standard form, *p.* 56
minimum value, *p.* 58
maximum value, *p.* 58
intercept form, *p.* 59

Core Concepts

Section 2.1

Horizontal Translations, *p.* 48
Vertical Translations, *p.* 48
Reflections in the *x*-Axis, *p.* 49

Reflections in the *y*-Axis, *p.* 49
Horizontal Stretches and Shrinks, *p.* 49
Vertical Stretches and Shrinks, *p.* 49

Section 2.2

Properties of the Graph of $f(x) = ax^2 + bx + c$,
p. 57
Minimum and Maximum Values, *p.* 58

Properties of the Graph of $f(x) = a(x - p)(x - q)$,
p. 59

Mathematical Practices

1. Why does the height you found in Exercise 44 on page 53 make sense in the context of the situation?
2. How can you effectively communicate your preference in methods to others in Exercise 47 on page 54?
3. How can you use technology to deepen your understanding of the concepts in Exercise 79 on page 64?

Study Skills

Using the Features of Your Textbook to Prepare for Quizzes and Tests

- Read and understand the core vocabulary and the contents of the Core Concept boxes.
- Review the Examples and the Monitoring Progress questions. Use the tutorials at BigIdeasMath.com for additional help.
- Review previously completed homework assignments.



2.1–2.2 Quiz

Describe the transformation of $f(x) = x^2$ represented by g . (Section 2.1)

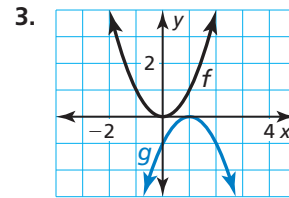
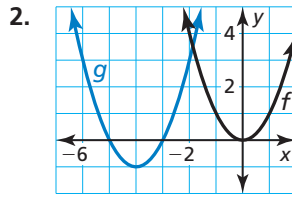
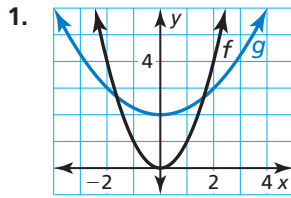

Write a rule for g and identify the vertex. (Section 2.1)

- Let g be a translation 2 units up followed by a reflection in the x -axis and a vertical stretch by a factor of 6 of the graph of $f(x) = x^2$.
- Let g be a translation 1 unit left and 6 units down, followed by a vertical shrink by a factor of $\frac{1}{2}$ of the graph of $f(x) = 3(x + 2)^2$.
- Let g be a horizontal shrink by a factor of $\frac{1}{4}$, followed by a translation 1 unit up and 3 units right of the graph of $f(x) = (2x + 1)^2 - 11$.

Graph the function. Label the vertex and axis of symmetry. (Section 2.2)

7. $f(x) = 2(x - 1)^2 - 5$

8. $h(x) = 3x^2 + 6x - 2$

9. $f(x) = 7 - 8x - x^2$

Find the x -intercepts of the graph of the function. Then describe where the function is increasing and decreasing. (Section 2.2)

10. $g(x) = -3(x + 2)(x + 4)$

11. $g(x) = \frac{1}{2}(x - 5)(x + 1)$

12. $f(x) = 0.4x(x - 6)$

13. A grasshopper can jump incredible distances, up to 20 times its length. The height (in inches) of the jump above the ground of a 1-inch-long grasshopper is given by $h(x) = -\frac{1}{20}x^2 + x$, where x is the horizontal distance (in inches) of the jump. When the grasshopper jumps off a rock, it lands on the ground 2 inches farther. Write a function that models the new path of the jump. (Section 2.1)

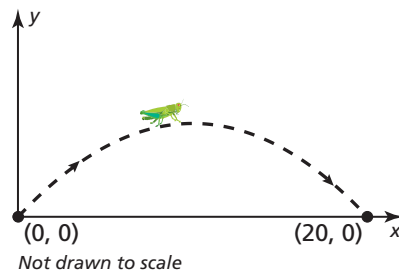

14. A passenger on a stranded lifeboat shoots a distress flare into the air. The height (in feet) of the flare above the water is given by $f(t) = -16t(t - 8)$, where t is time (in seconds) since the flare was shot. The passenger shoots a second flare, whose path is modeled in the graph. Which flare travels higher? Which remains in the air longer? Justify your answer. (Section 2.2)

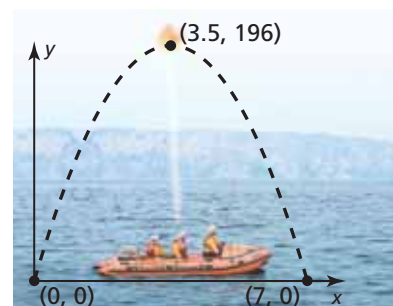

2.3 Focus of a Parabola

Essential Question What is the focus of a parabola?

EXPLORATION 1 Analyzing Satellite Dishes

Work with a partner. Vertical rays enter a satellite dish whose cross section is a parabola. When the rays hit the parabola, they reflect at the same angle at which they entered. (See Ray 1 in the figure.)

- Draw the reflected rays so that they intersect the y -axis.
- What do the reflected rays have in common?
- The optimal location for the receiver of the satellite dish is at a point called the *focus* of the parabola. Determine the location of the focus. Explain why this makes sense in this situation.

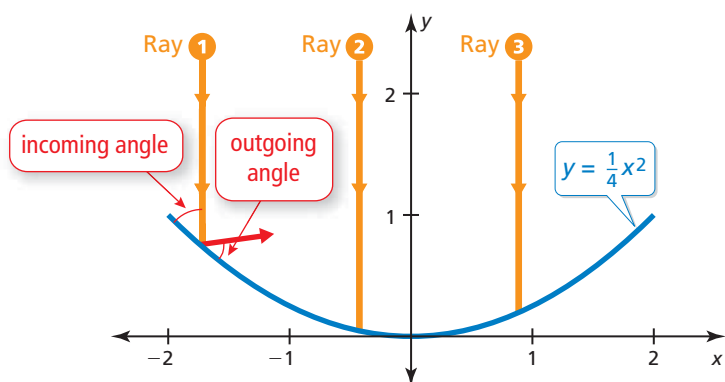

CONSTRUCTING VIABLE ARGUMENTS

To be proficient in math, you need to make conjectures and build logical progressions of statements to explore the truth of your conjectures.

EXPLORATION 2 Analyzing Spotlights

Work with a partner. Beams of light are coming from the bulb in a spotlight, located at the focus of the parabola. When the beams hit the parabola, they reflect at the same angle at which they hit. (See Beam 1 in the figure.) Draw the reflected beams. What do they have in common? Would you consider this to be the optimal result? Explain.

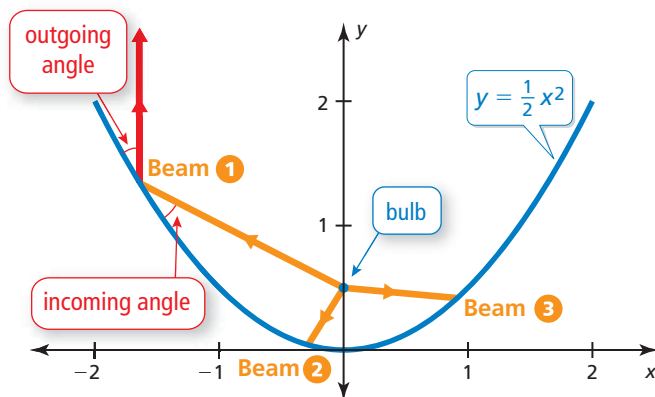

Communicate Your Answer

- What is the focus of a parabola?
- Describe some of the properties of the focus of a parabola.

2.3 Lesson

Core Vocabulary

focus, p. 68
directrix, p. 68

Previous
perpendicular
Distance Formula
congruent

What You Will Learn

- ▶ Explore the focus and the directrix of a parabola.
- ▶ Write equations of parabolas.
- ▶ Solve real-life problems.

Exploring the Focus and Directrix

Previously, you learned that the graph of a quadratic function is a parabola that opens up or down. A parabola can also be defined as the set of all points (x, y) in a plane that are equidistant from a fixed point called the **focus** and a fixed line called the **directrix**.

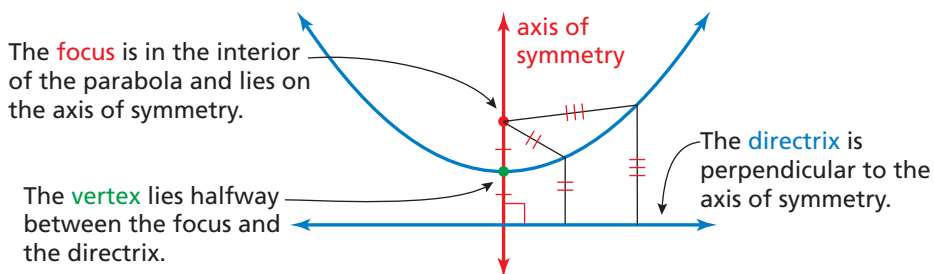

STUDY TIP

The distance from a point to a line is defined as the length of the perpendicular segment from the point to the line.

EXAMPLE 1 Using the Distance Formula to Write an Equation

Use the Distance Formula to write an equation of the parabola with focus $F(0, 2)$ and directrix $y = -2$.

SOLUTION

Notice the line segments drawn from point F to point P and from point P to point D . By the definition of a parabola, these line segments must be congruent.

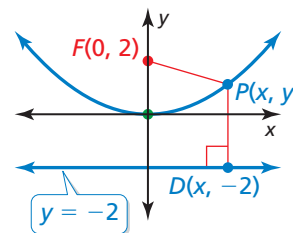

Definition of a parabola

Distance Formula

Substitute for $x_1, y_1, x_2,$ and y_2 .

Simplify.

Square each side.

Expand.

Combine like terms.

Divide each side by 8.

$$\begin{aligned}
 PD &= PF \\
 \sqrt{(x - x_1)^2 + (y - y_1)^2} &= \sqrt{(x - x_2)^2 + (y - y_2)^2} \\
 \sqrt{(x - 0)^2 + (y - (-2))^2} &= \sqrt{(x - 0)^2 + (y - 2)^2} \\
 \sqrt{(y + 2)^2} &= \sqrt{x^2 + (y - 2)^2} \\
 (y + 2)^2 &= x^2 + (y - 2)^2 \\
 y^2 + 4y + 4 &= x^2 + y^2 - 4y + 4 \\
 8y &= x^2 \\
 y &= \frac{1}{8}x^2
 \end{aligned}$$

Monitoring Progress



Help in English and Spanish at BigIdeasMath.com

1. Use the Distance Formula to write an equation of the parabola with focus $F(0, -3)$ and directrix $y = 3$.

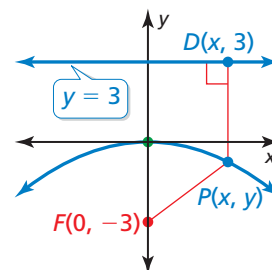

You can derive the equation of a parabola that opens up or down with vertex $(0, 0)$, focus $(0, p)$, and directrix $y = -p$ using the procedure in Example 1.

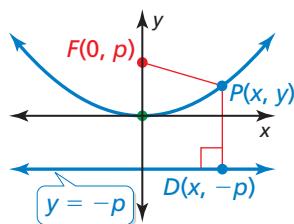

$$\begin{aligned}\sqrt{(x - 0)^2 + (y - (-p))^2} &= \sqrt{(x - 0)^2 + (y - p)^2} \\ (y + p)^2 &= x^2 + (y - p)^2 \\ y^2 + 2py + p^2 &= x^2 + y^2 - 2py + p^2 \\ 4py &= x^2 \\ y &= \frac{1}{4p}x^2\end{aligned}$$

LOOKING FOR STRUCTURE

Notice that $y = \frac{1}{4p}x^2$ is of the form $y = ax^2$. So, changing the value of p vertically stretches or shrinks the parabola.

The focus and directrix each lie $|p|$ units from the vertex. Parabolas can also open left or right, in which case the equation has the form $x = \frac{1}{4p}y^2$ when the vertex is $(0, 0)$.

Core Concept

Standard Equations of a Parabola with Vertex at the Origin

Vertical axis of symmetry ($x = 0$)

Equation: $y = \frac{1}{4p}x^2$

Focus: $(0, p)$

Directrix: $y = -p$

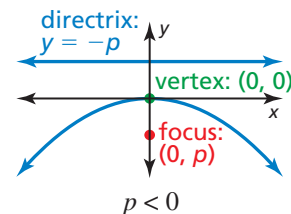
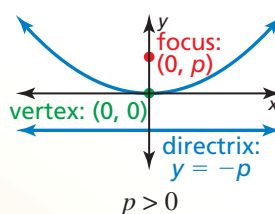

Horizontal axis of symmetry ($y = 0$)

Equation: $x = \frac{1}{4p}y^2$

Focus: $(p, 0)$

Directrix: $x = -p$

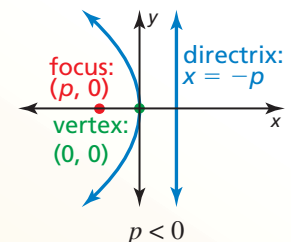
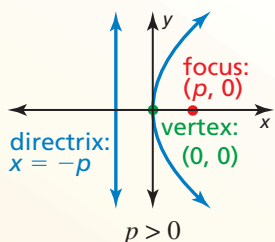

STUDY TIP

Notice that parabolas opening left or right do *not* represent functions.

EXAMPLE 2 Graphing an Equation of a Parabola

Identify the focus, directrix, and axis of symmetry of $-4x = y^2$. Graph the equation.

SOLUTION

Step 1 Rewrite the equation in standard form.

$$\begin{aligned}-4x &= y^2 && \text{Write the original equation.} \\ x &= -\frac{1}{4}y^2 && \text{Divide each side by } -4.\end{aligned}$$

Step 2 Identify the focus, directrix, and axis of symmetry. The equation has the form $x = \frac{1}{4p}y^2$, where $p = -1$. The focus is $(p, 0)$, or $(-1, 0)$. The directrix is $x = -p$, or $x = 1$. Because y is squared, the axis of symmetry is the x -axis.

Step 3 Use a table of values to graph the equation. Notice that it is easier to substitute y -values and solve for x . Opposite y -values result in the same x -value.

y	0	± 1	± 2	± 3	± 4
x	0	-0.25	-1	-2.25	-4

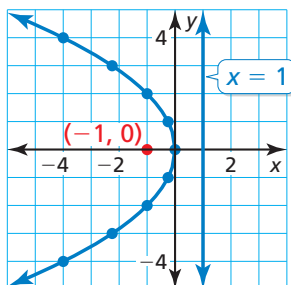

Writing Equations of Parabolas

EXAMPLE 3 Writing an Equation of a Parabola

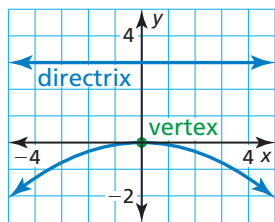

Write an equation of the parabola shown.

SOLUTION

Because the vertex is at the origin and the axis of symmetry is vertical, the equation has the form $y = \frac{1}{4p}x^2$. The directrix is $y = -p = 3$, so $p = -3$. Substitute -3 for p to write an equation of the parabola.

$$y = \frac{1}{4(-3)}x^2 = -\frac{1}{12}x^2$$

▶ So, an equation of the parabola is $y = -\frac{1}{12}x^2$.

Monitoring Progress Help in English and Spanish at BigIdeasMath.com

Identify the focus, directrix, and axis of symmetry of the parabola. Then graph the equation.

2. $y = 0.5x^2$

3. $-y = x^2$

4. $y^2 = 6x$

Write an equation of the parabola with vertex at $(0, 0)$ and the given directrix or focus.

5. directrix: $x = -3$

6. focus: $(-2, 0)$

7. focus: $(0, \frac{3}{2})$

The vertex of a parabola is not always at the origin. As in previous transformations, adding a value to the input or output of a function translates its graph.

Core Concept

Standard Equations of a Parabola with Vertex at (h, k)

Vertical axis of symmetry ($x = h$)

Equation: $y = \frac{1}{4p}(x - h)^2 + k$

Focus: $(h, k + p)$

Directrix: $y = k - p$

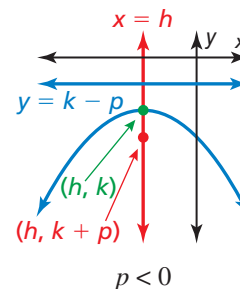
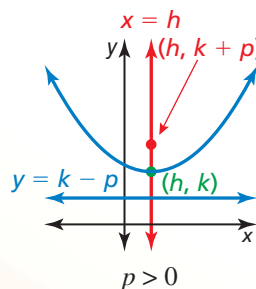

Horizontal axis of symmetry ($y = k$)

Equation: $x = \frac{1}{4p}(y - k)^2 + h$

Focus: $(h + p, k)$

Directrix: $x = h - p$

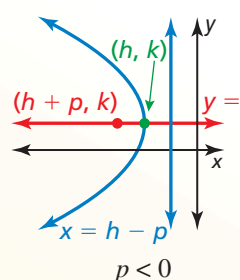
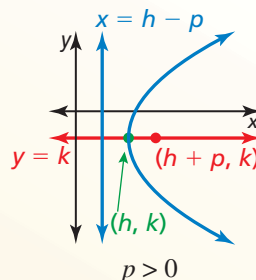

STUDY TIP

The standard form for a vertical axis of symmetry looks like vertex form. To remember the standard form for a horizontal axis of symmetry, switch x and y , and h and k .

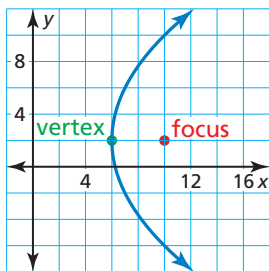
EXAMPLE 4**Writing an Equation of a Translated Parabola**

Write an equation of the parabola shown.

SOLUTION

Because the vertex is not at the origin and the axis of symmetry is horizontal, the equation has the form $x = \frac{1}{4p}(y - k)^2 + h$. The vertex (h, k) is $(6, 2)$ and the focus $(h + p, k)$ is $(10, 2)$, so $h = 6$, $k = 2$, and $p = 4$. Substitute these values to write an equation of the parabola.

$$x = \frac{1}{4(4)}(y - 2)^2 + 6 = \frac{1}{16}(y - 2)^2 + 6$$

► So, an equation of the parabola is $x = \frac{1}{16}(y - 2)^2 + 6$.

Solving Real-Life Problems

Parabolic reflectors have cross sections that are parabolas. Incoming sound, light, or other energy that arrives at a parabolic reflector parallel to the axis of symmetry is directed to the focus (Diagram 1). Similarly, energy that is emitted from the focus of a parabolic reflector and then strikes the reflector is directed parallel to the axis of symmetry (Diagram 2).

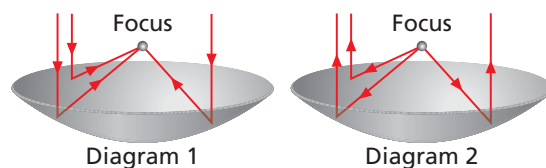
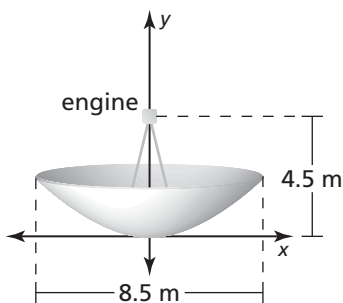
**EXAMPLE 5****Solving a Real-Life Problem**

An electricity-generating dish uses a parabolic reflector to concentrate sunlight onto a high-frequency engine located at the focus of the reflector. The sunlight heats helium to 650°C to power the engine. Write an equation that represents the cross section of the dish shown with its vertex at $(0, 0)$. What is the depth of the dish?

SOLUTION

Because the vertex is at the origin, and the axis of symmetry is vertical, the equation has the form $y = \frac{1}{4p}x^2$. The engine is at the focus, which is 4.5 meters above the vertex. So, $p = 4.5$. Substitute 4.5 for p to write the equation.

$$y = \frac{1}{4(4.5)}x^2 = \frac{1}{18}x^2$$

The depth of the dish is the y -value at the dish's outside edge. The dish extends $\frac{8.5}{2} = 4.25$ meters to either side of the vertex $(0, 0)$, so find y when $x = 4.25$.

$$y = \frac{1}{18}(4.25)^2 \approx 1$$

► The depth of the dish is about 1 meter.

Monitoring Progress [Help in English and Spanish at BigIdeasMath.com](http://BigIdeasMath.com)

8. Write an equation of a parabola with vertex $(-1, 4)$ and focus $(-1, 2)$.
9. A parabolic microwave antenna is 16 feet in diameter. Write an equation that represents the cross section of the antenna with its vertex at $(0, 0)$ and its focus 10 feet to the right of the vertex. What is the depth of the antenna?

2.3 Exercises

Dynamic Solutions available at BigIdeasMath.com

Vocabulary and Core Concept Check

- COMPLETE THE SENTENCE** A parabola is the set of all points in a plane equidistant from a fixed point called the _____ and a fixed line called the _____.
- WRITING** Explain how to find the coordinates of the focus of a parabola with vertex $(0, 0)$ and directrix $y = 5$.

Monitoring Progress and Modeling with Mathematics

In Exercises 3–10, use the Distance Formula to write an equation of the parabola. (See Example 1.)

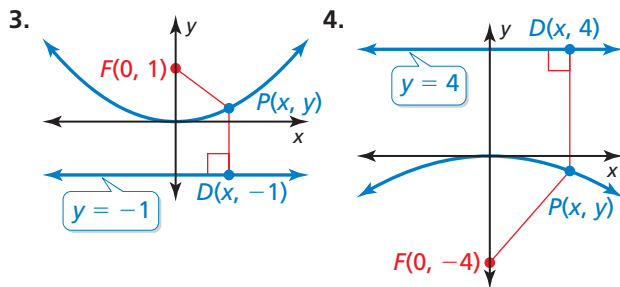

- focus: $(0, -2)$
directrix: $y = 2$
- vertex: $(0, 0)$
directrix: $y = -6$
- vertex: $(0, 0)$
focus: $(0, 5)$
- vertex: $(0, 0)$
focus: $(0, -10)$
- directrix: $y = 7$
focus: $(0, -7)$
- vertex: $(0, 0)$
focus: $(0, 5)$
- vertex: $(0, 0)$
directrix: $y = -9$

11. **ANALYZING RELATIONSHIPS** Which of the given characteristics describe parabolas that open down? Explain your reasoning.

- | | |
|--|--|
| (A) focus: $(0, -6)$
directrix: $y = 6$ | (B) focus: $(0, -2)$
directrix: $y = 2$ |
| (C) focus: $(0, 6)$
directrix: $y = -6$ | (D) focus: $(0, -1)$
directrix: $y = 1$ |

12. **REASONING** Which of the following are possible coordinates of the point P in the graph shown? Explain.

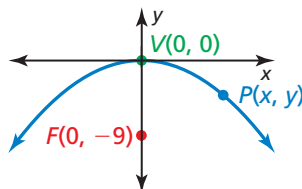

- | | | |
|-------------------------|-------------------------|--------------------------|
| (A) $(-6, -1)$ | (B) $(3, -\frac{1}{4})$ | (C) $(4, -\frac{4}{9})$ |
| (D) $(1, \frac{1}{36})$ | (E) $(6, -1)$ | (F) $(2, -\frac{1}{18})$ |

In Exercises 13–20, identify the focus, directrix, and axis of symmetry of the parabola. Graph the equation. (See Example 2.)

- | | |
|----------------------------|----------------------------|
| 13. $y = \frac{1}{8}x^2$ | 14. $y = -\frac{1}{12}x^2$ |
| 15. $x = -\frac{1}{20}y^2$ | 16. $x = \frac{1}{24}y^2$ |
| 17. $y^2 = 16x$ | 18. $-x^2 = 48y$ |
| 19. $6x^2 + 3y = 0$ | 20. $8x^2 - y = 0$ |

ERROR ANALYSIS In Exercises 21 and 22, describe and correct the error in graphing the parabola.

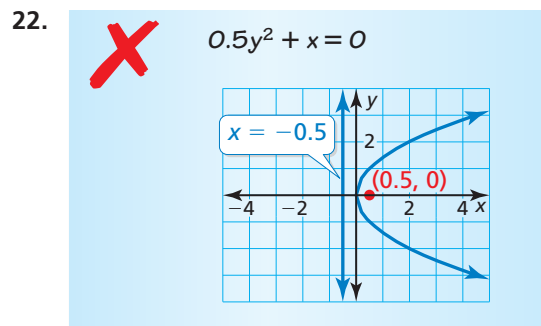
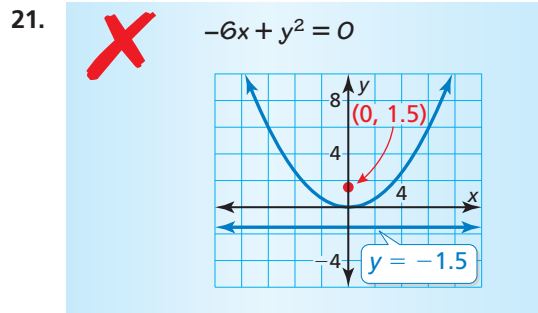

23. **ANALYZING EQUATIONS** The cross section (with units in inches) of a parabolic satellite dish can be modeled by the equation $y = \frac{1}{38}x^2$. How far is the receiver from the vertex of the cross section? Explain.

- 24. ANALYZING EQUATIONS** The cross section (with units in inches) of a parabolic spotlight can be modeled by the equation $x = \frac{1}{20}y^2$. How far is the bulb from the vertex of the cross section? Explain.



In Exercises 25–28, write an equation of the parabola shown. (See Example 3.)

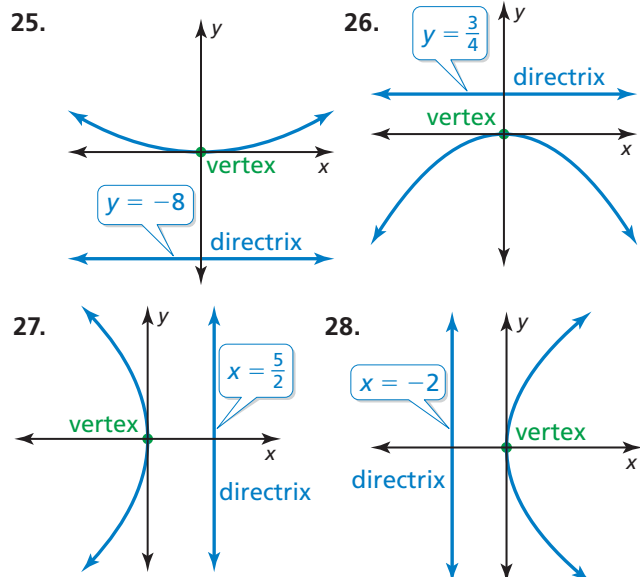

In Exercises 29–36, write an equation of the parabola with the given characteristics.

- | | |
|--|--|
| 29. focus: (3, 0)
directrix: $x = -3$ | 30. focus: $(\frac{2}{3}, 0)$
directrix: $x = -\frac{2}{3}$ |
| 31. directrix: $x = -10$
vertex: (0, 0) | 32. directrix: $y = \frac{8}{3}$
vertex: (0, 0) |
| 33. focus: $(0, -\frac{5}{3})$
directrix: $y = \frac{5}{3}$ | 34. focus: $(0, \frac{5}{4})$
directrix: $y = -\frac{5}{4}$ |
| 35. focus: $(0, \frac{6}{7})$
vertex: (0, 0) | 36. focus: $(-\frac{4}{5}, 0)$
vertex: (0, 0) |

In Exercises 37–40, write an equation of the parabola shown. (See Example 4.)

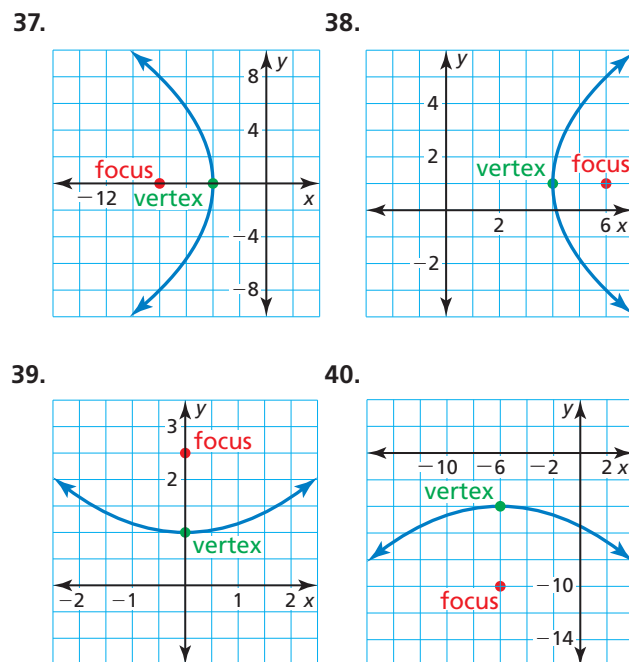

In Exercises 41–46, identify the vertex, focus, directrix, and axis of symmetry of the parabola. Describe the transformations of the graph of the standard equation with $p = 1$ and vertex (0, 0).

41. $y = \frac{1}{8}(x - 3)^2 + 2$ 42. $y = -\frac{1}{4}(x + 2)^2 + 1$
 43. $x = \frac{1}{16}(y - 3)^2 + 1$ 44. $y = (x + 3)^2 - 5$
 45. $x = -3(y + 4)^2 + 2$ 46. $x = 4(y + 5)^2 - 1$

- 47. MODELING WITH MATHEMATICS** Scientists studying dolphin echolocation simulate the projection of a bottlenose dolphin's clicking sounds using computer models. The models originate the sounds at the focus of a parabolic reflector. The parabola in the graph shows the cross section of the reflector with focal length of 1.3 inches and aperture width of 8 inches. Write an equation to represent the cross section of the reflector. What is the depth of the reflector? (See Example 5.)

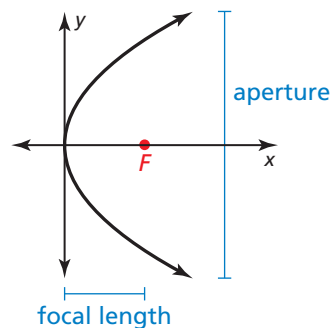

48. **MODELING WITH MATHEMATICS** Solar energy can be concentrated using long troughs that have a parabolic cross section as shown in the figure. Write an equation to represent the cross section of the trough. What are the domain and range in this situation? What do they represent?

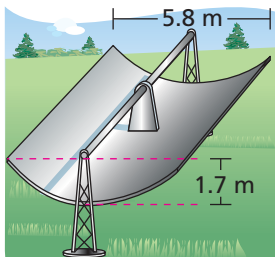

49. **ABSTRACT REASONING** As $|p|$ increases, how does the width of the graph of the equation $y = \frac{1}{4p}x^2$ change? Explain your reasoning.

50. **HOW DO YOU SEE IT?** The graph shows the path of a volleyball served from an initial height of 6 feet as it travels over a net.

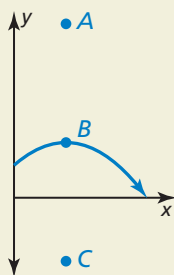

- Label the vertex, focus, and a point on the directrix.
- An underhand serve follows the same parabolic path but is hit from a height of 3 feet. How does this affect the focus? the directrix?

51. **CRITICAL THINKING** The distance from point P to the directrix is 2 units. Write an equation of the parabola.

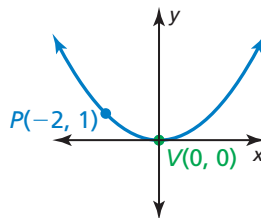

52. **THOUGHT PROVOKING** Two parabolas have the same focus (a, b) and focal length of 2 units. Write an equation of each parabola. Identify the directrix of each parabola.

53. **REPEATED REASONING** Use the Distance Formula to derive the equation of a parabola that opens to the right with vertex $(0, 0)$, focus $(p, 0)$, and directrix $x = -p$.

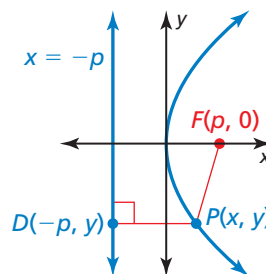

54. **PROBLEM SOLVING** The *latus rectum* of a parabola is the line segment that is parallel to the directrix, passes through the focus, and has endpoints that lie on the parabola. Find the length of the latus rectum of the parabola shown.

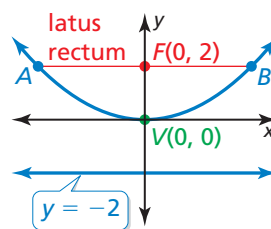

Maintaining Mathematical Proficiency Reviewing what you learned in previous grades and lessons

Write an equation of the line that passes through the points. (Section 1.3)

55. $(1, -4), (2, -1)$ 56. $(-3, 12), (0, 6)$ 57. $(3, 1), (-5, 5)$ 58. $(2, -1), (0, 1)$

Use a graphing calculator to find an equation for the line of best fit. (Section 1.3)

59.

x	0	3	6	7	11
y	4	9	24	29	46

60.

x	0	5	10	12	16
y	18	15	9	7	2

2.4 Modeling with Quadratic Functions

Essential Question How can you use a quadratic function to model a real-life situation?

EXPLORATION 1 Modeling with a Quadratic Function

Work with a partner. The graph shows a quadratic function of the form

$$P(t) = at^2 + bt + c$$

which approximates the yearly profits for a company, where $P(t)$ is the profit in year t .

- Is the value of a positive, negative, or zero? Explain.
- Write an expression in terms of a and b that represents the year t when the company made the least profit.
- The company made the same yearly profits in 2004 and 2012. Estimate the year in which the company made the least profit.
- Assume that the model is still valid today. Are the yearly profits currently increasing, decreasing, or constant? Explain.

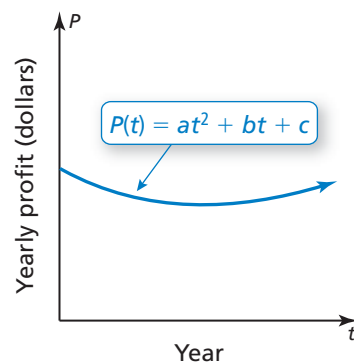

EXPLORATION 2 Modeling with a Graphing Calculator

Work with a partner. The table shows the heights h (in feet) of a wrench t seconds after it has been dropped from a building under construction.

Time, t	0	1	2	3	4
Height, h	400	384	336	256	144

- Use a graphing calculator to create a scatter plot of the data, as shown at the right. Explain why the data appear to fit a quadratic model.
- Use the *quadratic regression* feature to find a quadratic model for the data.
- Graph the quadratic function on the same screen as the scatter plot to verify that it fits the data.
- When does the wrench hit the ground? Explain.

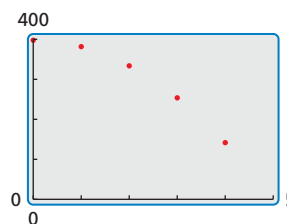

MODELING WITH MATHEMATICS

To be proficient in math, you need to routinely interpret your results in the context of the situation.

Communicate Your Answer

- How can you use a quadratic function to model a real-life situation?
- Use the Internet or some other reference to find examples of real-life situations that can be modeled by quadratic functions.

2.4 Lesson

Core Vocabulary

Previous

average rate of change
system of three linear
equations

What You Will Learn

- ▶ Write equations of quadratic functions using vertices, points, and x-intercepts.
- ▶ Write quadratic equations to model data sets.

Writing Quadratic Equations

Core Concept

Writing Quadratic Equations

Given a point and the vertex (h, k)

Use vertex form:

$$y = a(x - h)^2 + k$$

Given a point and x-intercepts p and q

Use intercept form:

$$y = a(x - p)(x - q)$$

Given three points

Write and solve a system of three equations in three variables.

EXAMPLE 1

Writing an Equation Using a Vertex and a Point

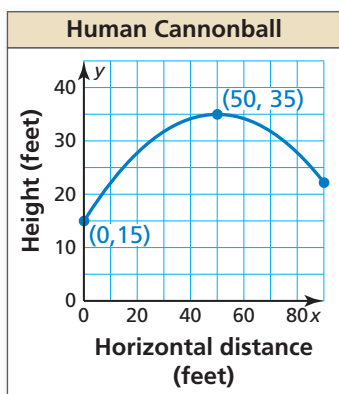

The graph shows the parabolic path of a performer who is shot out of a cannon, where y is the height (in feet) and x is the horizontal distance traveled (in feet). Write an equation of the parabola. The performer lands in a net 90 feet from the cannon. What is the height of the net?

SOLUTION

From the graph, you can see that the vertex (h, k) is $(50, 35)$ and the parabola passes through the point $(0, 15)$. Use the vertex and the point to solve for a in vertex form.

$$y = a(x - h)^2 + k$$

Vertex form

$$15 = a(0 - 50)^2 + 35$$

Substitute for $h, k, x,$ and y .

$$-20 = 2500a$$

Simplify.

$$-0.008 = a$$

Divide each side by 2500.

Because $a = -0.008$, $h = 50$, and $k = 35$, the path can be modeled by the equation $y = -0.008(x - 50)^2 + 35$, where $0 \leq x \leq 90$. Find the height when $x = 90$.

$$y = -0.008(90 - 50)^2 + 35$$

Substitute 90 for x .

$$= -0.008(1600) + 35$$

Simplify.

$$= 22.2$$

Simplify.

- ▶ So, the height of the net is about 22 feet.

Monitoring Progress



Help in English and Spanish at BigIdeasMath.com

1. **WHAT IF?** The vertex of the parabola is $(50, 37.5)$. What is the height of the net?
2. Write an equation of the parabola that passes through the point $(-1, 2)$ and has vertex $(4, -9)$.

EXAMPLE 2

Writing an Equation Using a Point and x -Intercepts

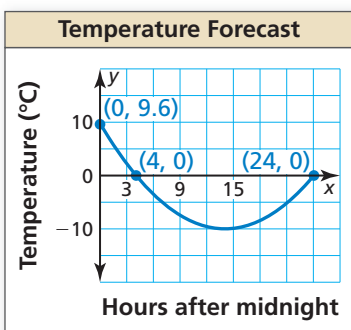

A meteorologist creates a parabola to predict the temperature tomorrow, where x is the number of hours after midnight and y is the temperature (in degrees Celsius).

- Write a function f that models the temperature over time. What is the coldest temperature?
- What is the average rate of change in temperature over the interval in which the temperature is decreasing? increasing? Compare the average rates of change.

SOLUTION

- The x -intercepts are 4 and 24 and the parabola passes through $(0, 9.6)$. Use the x -intercepts and the point to solve for a in intercept form.

$$y = a(x - p)(x - q) \quad \text{Intercept form}$$

$$9.6 = a(0 - 4)(0 - 24) \quad \text{Substitute for } p, q, x, \text{ and } y.$$

$$9.6 = 96a \quad \text{Simplify.}$$

$$0.1 = a \quad \text{Divide each side by 96.}$$

Because $a = 0.1$, $p = 4$, and $q = 24$, the temperature over time can be modeled by $f(x) = 0.1(x - 4)(x - 24)$, where $0 \leq x \leq 24$. The coldest temperature is the minimum value. So, find $f(x)$ when $x = \frac{4 + 24}{2} = 14$.

$$f(14) = 0.1(14 - 4)(14 - 24) \quad \text{Substitute 14 for } x.$$

$$= -10 \quad \text{Simplify.}$$

► So, the coldest temperature is -10°C at 14 hours after midnight, or 2 P.M.

- The parabola opens up and the axis of symmetry is $x = 14$. So, the function is decreasing over the interval $0 < x < 14$ and increasing over the interval $14 < x < 24$.

Average rate of change
over $0 < x < 14$:

$$\frac{f(14) - f(0)}{14 - 0} = \frac{-10 - 9.6}{14} = -1.4$$

Average rate of change
over $14 < x < 24$:

$$\frac{f(24) - f(14)}{24 - 14} = \frac{0 - (-10)}{10} = 1$$

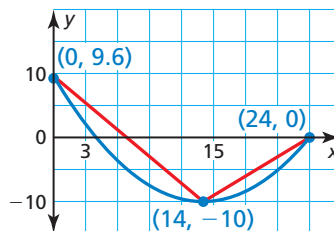

► Because $|-1.4| > |1|$, the average rate at which the temperature decreases from midnight to 2 P.M. is greater than the average rate at which it increases from 2 P.M. to midnight.

REMEMBER

The average rate of change of a function f from x_1 to x_2 is the slope of the line connecting $(x_1, f(x_1))$ and $(x_2, f(x_2))$:

$$\frac{f(x_2) - f(x_1)}{x_2 - x_1}$$



Monitoring Progress



Help in English and Spanish at BigIdeasMath.com

- WHAT IF?** The y -intercept is 4.8. How does this change your answers in parts (a) and (b)?
- Write an equation of the parabola that passes through the point $(2, 5)$ and has x -intercepts -2 and 4 .

Writing Equations to Model Data

When data have equally-spaced inputs, you can analyze patterns in the differences of the outputs to determine what type of function can be used to model the data. Linear data have constant *first differences*. Quadratic data have constant *second differences*. The first and second differences of $f(x) = x^2$ are shown below.

Equally-spaced x -values

x	-3	-2	-1	0	1	2	3
$f(x)$	9	4	1	0	1	4	9

first differences: -5 -3 -1 1 3 5

second differences: 2 2 2 2 2

EXAMPLE 3 Writing a Quadratic Equation Using Three Points

Time, t	Height, h
10	26,900
15	29,025
20	30,600
25	31,625
30	32,100
35	32,025
40	31,400

NASA can create a weightless environment by flying a plane in parabolic paths. The table shows heights h (in feet) of a plane t seconds after starting the flight path. After about 20.8 seconds, passengers begin to experience a weightless environment. Write and evaluate a function to approximate the height at which this occurs.

SOLUTION

Step 1 The input values are equally spaced. So, analyze the differences in the outputs to determine what type of function you can use to model the data.

$h(10)$	$h(15)$	$h(20)$	$h(25)$	$h(30)$	$h(35)$	$h(40)$
26,900	29,025	30,600	31,625	32,100	32,025	31,400

2125 1575 1025 475 -75 -625

-550 -550 -550 -550 -550

Because the second differences are constant, you can model the data with a quadratic function.

Step 2 Write a quadratic function of the form $h(t) = at^2 + bt + c$ that models the data. Use any three points (t, h) from the table to write a system of equations.

Use (10, 26,900): $100a + 10b + c = 26,900$ Equation 1

Use (20, 30,600): $400a + 20b + c = 30,600$ Equation 2

Use (30, 32,100): $900a + 30b + c = 32,100$ Equation 3

Use the elimination method to solve the system.

Subtract Equation 1 from Equation 2.

$$\rightarrow 300a + 10b = 3700$$

New Equation 1

Subtract Equation 1 from Equation 3.

$$\rightarrow 800a + 20b = 5200$$

New Equation 2

$$200a = -2200$$

Subtract 2 times new Equation 1 from new Equation 2.

$$a = -11$$

Solve for a .

$$b = 700$$

Substitute into new Equation 1 to find b .

$$c = 21,000$$

Substitute into Equation 1 to find c .

The data can be modeled by the function $h(t) = -11t^2 + 700t + 21,000$.

Step 3 Evaluate the function when $t = 20.8$.

$$h(20.8) = -11(20.8)^2 + 700(20.8) + 21,000 = 30,800.96$$

► Passengers begin to experience a weightless environment at about 30,800 feet.

Real-life data that show a quadratic relationship usually do not have constant second differences because the data are not *exactly* quadratic. Relationships that are *approximately* quadratic have second differences that are relatively “close” in value. Many technology tools have a *quadratic regression* feature that you can use to find a quadratic function that best models a set of data.

EXAMPLE 4 Using Quadratic Regression

Miles per hour, x	Miles per gallon, y
20	14.5
24	17.5
30	21.2
36	23.7
40	25.2
45	25.8
50	25.8
56	25.1
60	24.0
70	19.5

The table shows fuel efficiencies of a vehicle at different speeds. Write a function that models the data. Use the model to approximate the optimal driving speed.

SOLUTION

Because the x -values are not equally spaced, you cannot analyze the differences in the outputs. Use a graphing calculator to find a function that models the data.

Step 1 Enter the data in a graphing calculator using two lists and create a scatter plot. The data show a quadratic relationship.

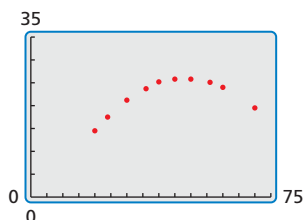

Step 2 Use the *quadratic regression* feature. A quadratic model that represents the data is $y = -0.014x^2 + 1.37x - 7.1$.

```
QuadReg
y=ax^2+bx+c
a=-.014097349
b=1.366218867
c=-7.144052413
R^2=.9992475882
```

STUDY TIP

The *coefficient of determination* R^2 shows how well an equation fits a set of data. The closer R^2 is to 1, the better the fit.

Step 3 Graph the regression equation with the scatter plot.

In this context, the “optimal” driving speed is the speed at which the mileage per gallon is maximized. Using the *maximum* feature, you can see that the maximum mileage per gallon is about 26.4 miles per gallon when driving about 48.9 miles per hour.

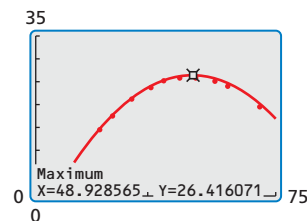

► So, the optimal driving speed is about 49 miles per hour.

Monitoring Progress Help in English and Spanish at BigIdeasMath.com

- Write an equation of the parabola that passes through the points $(-1, 4)$, $(0, 1)$, and $(2, 7)$.
- The table shows the estimated profits y (in dollars) for a concert when the charge is x dollars per ticket. Write and evaluate a function to determine what the charge per ticket should be to maximize the profit.

Ticket price, x	2	5	8	11	14	17
Profit, y	2600	6500	8600	8900	7400	4100

- The table shows the results of an experiment testing the maximum weights y (in tons) supported by ice x inches thick. Write a function that models the data. How much weight can be supported by ice that is 22 inches thick?

Ice thickness, x	12	14	15	18	20	24	27
Maximum weight, y	3.4	7.6	10.0	18.3	25.0	40.6	54.3

Vocabulary and Core Concept Check

- WRITING** Explain when it is appropriate to use a quadratic model for a set of data.
- DIFFERENT WORDS, SAME QUESTION** Which is different? Find “both” answers.

What is the average rate of change over $0 \leq x \leq 2$?

What is the distance from $f(0)$ to $f(2)$?

What is the slope of the line segment?

What is $\frac{f(2) - f(0)}{2 - 0}$?

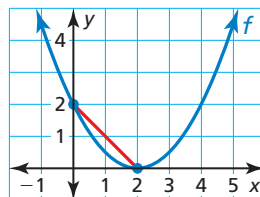

Monitoring Progress and Modeling with Mathematics

In Exercises 3–8, write an equation of the parabola in vertex form. (See Example 1.)

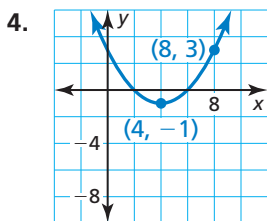
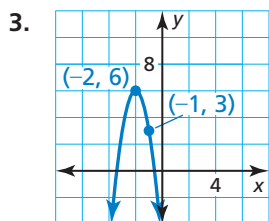

- passes through (13, 8) and has vertex (3, 2)
- passes through (-7, -15) and has vertex (-5, 9)
- passes through (0, -24) and has vertex (-6, -12)
- passes through (6, 35) and has vertex (-1, 14)

In Exercises 9–14, write an equation of the parabola in intercept form. (See Example 2.)

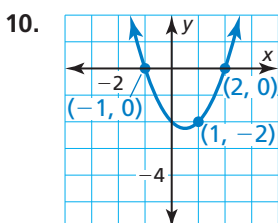
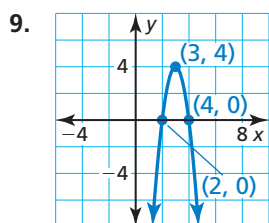

- x-intercepts of 12 and -6; passes through (14, 4)
- x-intercepts of 9 and 1; passes through (0, -18)
- x-intercepts of -16 and -2; passes through (-18, 72)
- x-intercepts of -7 and -3; passes through (-2, 0.05)

- WRITING** Explain when to use intercept form and when to use vertex form when writing an equation of a parabola.
- ANALYZING EQUATIONS** Which of the following equations represent the parabola?

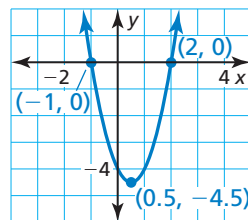

- $y = 2(x - 2)(x + 1)$
- $y = 2(x + 0.5)^2 - 4.5$
- $y = 2(x - 0.5)^2 - 4.5$
- $y = 2(x + 2)(x - 1)$

In Exercises 17–20, write an equation of the parabola in vertex form or intercept form.

17.

18.

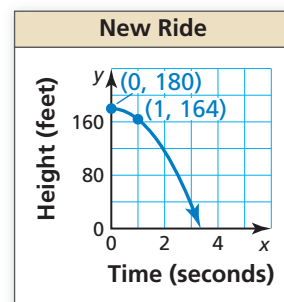
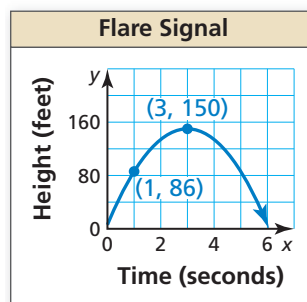

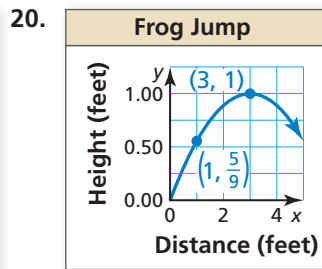
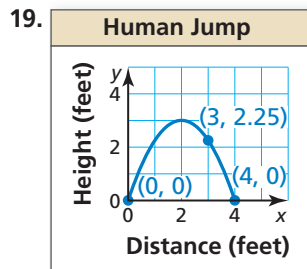

21. **ERROR ANALYSIS** Describe and correct the error in writing an equation of the parabola.

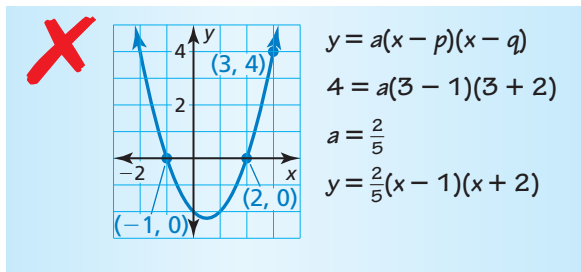

22. **MATHEMATICAL CONNECTIONS** The area of a rectangle is modeled by the graph where y is the area (in square meters) and x is the width (in meters). Write an equation of the parabola. Find the dimensions and corresponding area of one possible rectangle. What dimensions result in the maximum area?

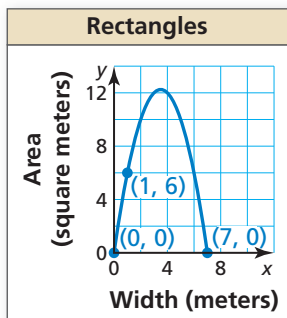

23. **MODELING WITH MATHEMATICS** Every rope has a safe working load. A rope should not be used to lift a weight greater than its safe working load. The table shows the safe working loads S (in pounds) for ropes with circumference C (in inches). Write an equation for the safe working load for a rope. Find the safe working load for a rope that has a circumference of 10 inches. (See Example 3.)

Circumference, C	0	1	2	3
Safe working load, S	0	180	720	1620

24. **MODELING WITH MATHEMATICS** A baseball is thrown up in the air. The table shows the heights y (in feet) of the baseball after x seconds. Write an equation for the path of the baseball. Find the height of the baseball after 5 seconds.

Time, x	0	2	4	6
Baseball height, y	6	22	22	6

25. **COMPARING METHODS** You use a system with three variables to find the equation of a parabola that passes through the points $(-8, 0)$, $(2, -20)$, and $(1, 0)$. Your friend uses intercept form to find the equation. Whose method is easier? Justify your answer.
26. **MODELING WITH MATHEMATICS** The table shows the distances y a motorcyclist is from home after x hours.

Time (hours), x	0	1	2	3
Distance (miles), y	0	45	90	135

- a. Determine what type of function you can use to model the data. Explain your reasoning.
- b. Write and evaluate a function to determine the distance the motorcyclist is from home after 6 hours.
27. **USING TOOLS** The table shows the heights h (in feet) of a sponge t seconds after it was dropped by a window cleaner on top of a skyscraper. (See Example 4.)
- | Time, t | 0 | 1 | 1.5 | 2.5 | 3 |
|-------------|-----|-----|-----|-----|-----|
| Height, h | 280 | 264 | 244 | 180 | 136 |
- a. Use a graphing calculator to create a scatter plot. Which better represents the data, a line or a parabola? Explain.
- b. Use the *regression* feature of your calculator to find the model that best fits the data.
- c. Use the model in part (b) to predict when the sponge will hit the ground.
- d. Identify and interpret the domain and range in this situation.
28. **MAKING AN ARGUMENT** Your friend states that quadratic functions with the same x -intercepts have the same equations, vertex, and axis of symmetry. Is your friend correct? Explain your reasoning.

In Exercises 29–32, analyze the differences in the outputs to determine whether the data are *linear*, *quadratic*, or *neither*. Explain. If linear or quadratic, write an equation that fits the data.

29.

Price decrease (dollars), x	0	5	10	15	20
Revenue (\$1000s), y	470	630	690	650	510

30.

Time (hours), x	0	1	2	3	4
Height (feet), y	40	42	44	46	48

31.

Time (hours), x	1	2	3	4	5
Population (hundreds), y	2	4	8	16	32

32.

Time (days), x	0	1	2	3	4
Height (feet), y	320	303	254	173	60

33. **PROBLEM SOLVING** The graph shows the number y of students absent from school due to the flu each day x .

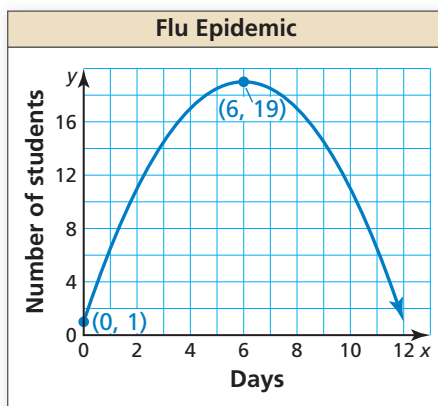

- Interpret the meaning of the vertex in this situation.
- Write an equation for the parabola to predict the number of students absent on day 10.
- Compare the average rates of change in the students with the flu from 0 to 6 days and 6 to 11 days.

34. **THOUGHT PROVOKING** Describe a real-life situation that can be modeled by a quadratic equation. Justify your answer.

35. **PROBLEM SOLVING** The table shows the heights y of a competitive water-skier x seconds after jumping off a ramp. Write a function that models the height of the water-skier over time. When is the water-skier 5 feet above the water? How long is the skier in the air?

Time (seconds), x	0	0.25	0.75	1	1.1
Height (feet), y	22	22.5	17.5	12	9.24

36. **HOW DO YOU SEE IT?** Use the graph to determine whether the average rate of change over each interval is *positive*, *negative*, or *zero*.

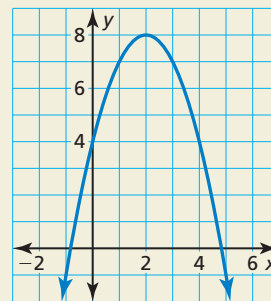

- $0 \leq x \leq 2$
- $2 \leq x \leq 5$
- $2 \leq x \leq 4$
- $0 \leq x \leq 4$

37. **REPEATED REASONING** The table shows the number of tiles in each figure. Verify that the data show a quadratic relationship. Predict the number of tiles in the 12th figure.

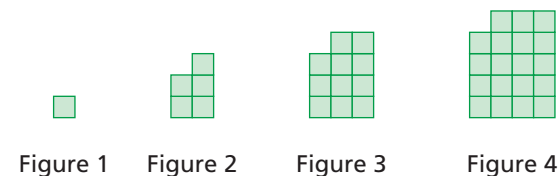

Figure	1	2	3	4
Number of Tiles	1	5	11	19

Maintaining Mathematical Proficiency Reviewing what you learned in previous grades and lessons

Factor the trinomial. (*Skills Review Handbook*)

38. $x^2 + 4x + 3$

39. $x^2 - 3x + 2$

40. $3x^2 - 15x + 12$

41. $5x^2 + 5x - 30$

2.3–2.4 What Did You Learn?

Core Vocabulary

focus, *p.* 68

directrix, *p.* 68

Core Concepts

Section 2.3

Standard Equations of a Parabola with Vertex at the Origin, *p.* 69

Standard Equations of a Parabola with Vertex at (h, k) , *p.* 70

Section 2.4

Writing Quadratic Equations, *p.* 76

Writing Quadratic Equations to Model Data, *p.* 78

Mathematical Practices

1. Explain the solution pathway you used to solve Exercise 47 on page 73.
2. Explain how you used definitions to derive the equation in Exercise 53 on page 74.
3. Explain the shortcut you found to write the equation in Exercise 25 on page 81.
4. Describe how you were able to construct a viable argument in Exercise 28 on page 81.

Performance Task

Accident Reconstruction

Was the driver of a car speeding when the brakes were applied? What do skid marks at the scene of an accident reveal about the moments before the collision?

To explore the answers to these questions and more, go to BigIdeasMath.com.



2.1 Transformations of Quadratic Functions (pp. 47–54)

Let the graph of g be a translation 1 unit left and 2 units up of the graph of $f(x) = x^2 + 1$. Write a rule for g .

$$\begin{aligned} g(x) &= f(x - (-1)) + 2 && \text{Subtract } -1 \text{ from the input. Add 2 to the output.} \\ &= (x + 1)^2 + 1 + 2 && \text{Replace } x \text{ with } x + 1 \text{ in } f(x). \\ &= x^2 + 2x + 4 && \text{Simplify.} \end{aligned}$$

► The transformed function is $g(x) = x^2 + 2x + 4$.

Describe the transformation of $f(x) = x^2$ represented by g . Then graph each function.

- $g(x) = (x + 4)^2$
- $g(x) = (x - 7)^2 + 2$
- $g(x) = -3(x + 2)^2 - 1$

Write a rule for g .

- Let the graph of g be a horizontal shrink by a factor of $\frac{2}{3}$, followed by a translation 5 units left and 2 units down of the graph of $f(x) = x^2$.
- Let the graph of g be a translation 2 units left and 3 units up, followed by a reflection in the y -axis of the graph of $f(x) = x^2 - 2x$.

2.2 Characteristics of Quadratic Functions (pp. 55–64)

Graph $f(x) = 2x^2 - 8x + 1$. Label the vertex and axis of symmetry.

Step 1 Identify the coefficients $a = 2$, $b = -8$, and $c = 1$. Because $a > 0$, the parabola opens up.

Step 2 Find the vertex. First calculate the x -coordinate.

$$x = -\frac{b}{2a} = -\frac{-8}{2(2)} = 2$$

Then find the y -coordinate of the vertex.

$$f(2) = 2(2)^2 - 8(2) + 1 = -7$$

So, the vertex is $(2, -7)$. Plot this point.

Step 3 Draw the axis of symmetry $x = 2$.

Step 4 Identify the y -intercept c , which is 1. Plot the point $(0, 1)$ and its reflection in the axis of symmetry, $(4, 1)$.

Step 5 Evaluate the function for another value of x , such as $x = 1$.

$$f(1) = 2(1)^2 - 8(1) + 1 = -5$$

Plot the point $(1, -5)$ and its reflection in the axis of symmetry, $(3, -5)$.

Step 6 Draw a parabola through the plotted points.

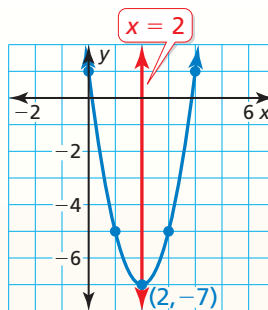

Graph the function. Label the vertex and axis of symmetry. Find the minimum or maximum value of f . Describe where the function is increasing and decreasing.

- $f(x) = 3(x - 1)^2 - 4$
- $g(x) = -2x^2 + 16x + 3$
- $h(x) = (x - 3)(x + 7)$

2.3 Focus of a Parabola (pp. 67–74)

- a. Identify the focus, directrix, and axis of symmetry of $8x = y^2$. Graph the equation.

Step 1 Rewrite the equation in standard form.

$$8x = y^2 \quad \text{Write the original equation.}$$

$$x = \frac{1}{8}y^2 \quad \text{Divide each side by 8.}$$

Step 2 Identify the focus, directrix, and axis of symmetry. The equation has the form $x = \frac{1}{4p}y^2$, where $p = 2$. The focus is $(p, 0)$, or $(2, 0)$. The directrix is $x = -p$, or $x = -2$. Because y is squared, the axis of symmetry is the x -axis.

Step 3 Use a table of values to graph the equation. Notice that it is easier to substitute y -values and solve for x .

y	0	± 2	± 4	± 6
x	0	0.5	2	4.5

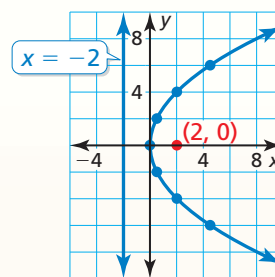

- b. Write an equation of the parabola shown.

Because the vertex is not at the origin and the axis of symmetry is vertical, the equation has the form $y = \frac{1}{4p}(x - h)^2 + k$. The vertex (h, k) is $(2, 3)$ and the focus $(h, k + p)$ is $(2, 4)$, so $h = 2$, $k = 3$, and $p = 1$. Substitute these values to write an equation of the parabola.

$$y = \frac{1}{4(1)}(x - 2)^2 + 3 = \frac{1}{4}(x - 2)^2 + 3$$

► An equation of the parabola is $y = \frac{1}{4}(x - 2)^2 + 3$.

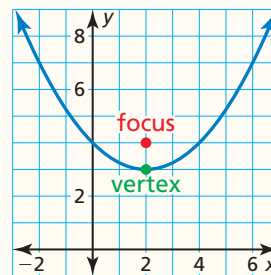

9. You can make a solar hot-dog cooker by shaping foil-lined cardboard into a parabolic trough and passing a wire through the focus of each end piece. For the trough shown, how far from the bottom should the wire be placed?
10. Graph the equation $36y = x^2$. Identify the focus, directrix, and axis of symmetry.

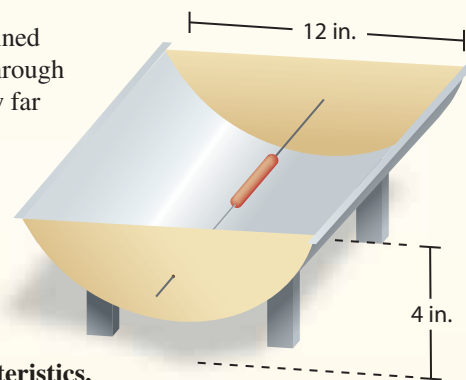

Write an equation of the parabola with the given characteristics.

11. vertex: $(0, 0)$
directrix: $x = 2$
12. focus: $(2, 2)$
vertex: $(2, 6)$

2.4 Modeling with Quadratic Functions (pp. 75–82)

The graph shows the parabolic path of a stunt motorcyclist jumping off a ramp, where y is the height (in feet) and x is the horizontal distance traveled (in feet). Write an equation of the parabola. The motorcyclist lands on another ramp 160 feet from the first ramp. What is the height of the second ramp?

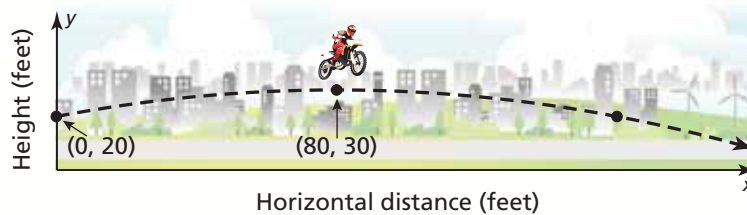

Step 1 First write an equation of the parabola.

From the graph, you can see that the vertex (h, k) is $(80, 30)$ and the parabola passes through the point $(0, 20)$. Use the vertex and the point to solve for a in vertex form.

$$y = a(x - h)^2 + k \quad \text{Vertex form}$$

$$20 = a(0 - 80)^2 + 30 \quad \text{Substitute for } h, k, x, \text{ and } y.$$

$$-10 = 6400a \quad \text{Simplify.}$$

$$-\frac{1}{640} = a \quad \text{Divide each side by 6400.}$$

Because $a = -\frac{1}{640}$, $h = 80$, and $k = 30$, the path can be modeled by

$$y = -\frac{1}{640}(x - 80)^2 + 30, \text{ where } 0 \leq x \leq 160.$$

Step 2 Then find the height of the second ramp.

$$y = -\frac{1}{640}(160 - 80)^2 + 30 \quad \text{Substitute 160 for } x.$$

$$= 20 \quad \text{Simplify.}$$

► So, the height of the second ramp is 20 feet.

Write an equation for the parabola with the given characteristics.

- passes through $(1, 12)$ and has vertex $(10, -4)$
- passes through $(4, 3)$ and has x -intercepts of -1 and 5
- passes through $(-2, 7)$, $(1, 10)$, and $(2, 27)$
- The table shows the heights y of a dropped object after x seconds. Verify that the data show a quadratic relationship. Write a function that models the data. How long is the object in the air?

Time (seconds), x	0	0.5	1	1.5	2	2.5
Height (feet), y	150	146	134	114	86	50

2 Chapter Test

1. A parabola has an axis of symmetry $y = 3$ and passes through the point $(2, 1)$. Find another point that lies on the graph of the parabola. Explain your reasoning.
2. Let the graph of g be a translation 2 units left and 1 unit down, followed by a reflection in the y -axis of the graph of $f(x) = (2x + 1)^2 - 4$. Write a rule for g .
3. Identify the focus, directrix, and axis of symmetry of $x = 2y^2$. Graph the equation.
4. Explain why a quadratic function models the data. Then use a linear system to find the model.

x	2	4	6	8	10
$f(x)$	0	-13	-34	-63	-100

Write an equation of the parabola. Justify your answer.

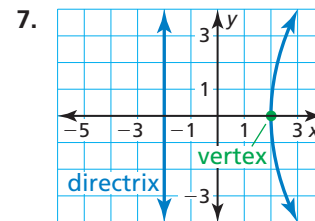
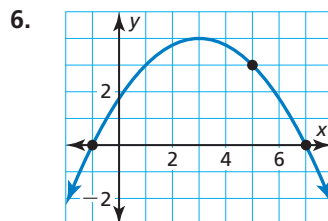
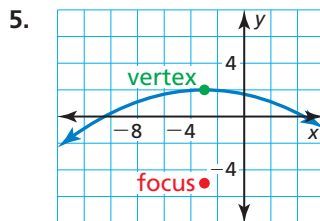

8. A surfboard shop sells 40 surfboards per month when it charges \$500 per surfboard. Each time the shop decreases the price by \$10, it sells 1 additional surfboard per month. How much should the shop charge per surfboard to maximize the amount of money earned? What is the maximum amount the shop can earn per month? Explain.
9. Graph $f(x) = 8x^2 - 4x + 3$. Label the vertex and axis of symmetry. Describe where the function is increasing and decreasing.
10. Sunfire is a machine with a parabolic cross section used to collect solar energy. The Sun's rays are reflected from the mirrors toward two boilers located at the focus of the parabola. The boilers produce steam that powers an alternator to produce electricity.
 - a. Write an equation that represents the cross section of the dish shown with its vertex at $(0, 0)$.
 - b. What is the depth of Sunfire? Justify your answer.
11. In 2011, the price of gold reached an all-time high. The table shows the prices (in dollars per troy ounce) of gold each year since 2006 ($t = 0$ represents 2006). Find a quadratic function that best models the data. Use the model to predict the price of gold in the year 2016.

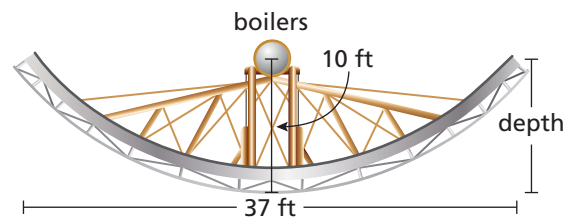

Year, t	0	1	2	3	4	5
Price, p	\$603.46	\$695.39	\$871.96	\$972.35	\$1224.53	\$1571.52

2

Cumulative Assessment

1. You and your friend are throwing a football. The parabola shows the path of your friend's throw, where x is the horizontal distance (in feet) and y is the corresponding height (in feet). The path of your throw can be modeled by $h(x) = -16x^2 + 65x + 5$. Choose the correct inequality symbol to indicate whose throw travels higher. Explain your reasoning.

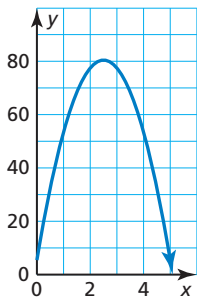

height of your throw height of your friend's throw

2. The function $g(x) = \frac{1}{2}|x - 4| + 4$ is a combination of transformations of $f(x) = |x|$. Which combinations describe the transformation from the graph of f to the graph of g ?
- (A) translation 4 units right and vertical shrink by a factor of $\frac{1}{2}$, followed by a translation 4 units up
- (B) translation 4 units right and 4 units up, followed by a vertical shrink by a factor of $\frac{1}{2}$
- (C) vertical shrink by a factor of $\frac{1}{2}$, followed by a translation 4 units up and 4 units right
- (D) translation 4 units right and 8 units up, followed by a vertical shrink by a factor of $\frac{1}{2}$
3. Your school decides to sell tickets to a dance in the school cafeteria to raise money. There is no fee to use the cafeteria, but the DJ charges a fee of \$750. The table shows the profits (in dollars) when x students attend the dance.

Students, x	Profit, y
100	-250
200	250
300	750
400	1250
500	1750

- a. What is the cost of a ticket?
- b. Your school expects 400 students to attend and finds another DJ who only charges \$650. How much should your school charge per ticket to still make the same profit?
- c. Your school decides to charge the amount in part (a) and use the less expensive DJ. How much more money will the school raise?
4. Order the following parabolas from widest to narrowest.
- A. focus: $(0, -3)$; directrix: $y = 3$
- B. $y = \frac{1}{16}x^2 + 4$
- C. $x = \frac{1}{8}y^2$
- D. $y = \frac{1}{4}(x - 2)^2 + 3$

5. Your friend claims that for $g(x) = b$, where b is a real number, there is a transformation in the graph that is impossible to notice. Is your friend correct? Explain your reasoning.
6. Let the graph of g represent a vertical stretch and a reflection in the x -axis, followed by a translation left and down of the graph of $f(x) = x^2$. Use the tiles to write a rule for g .

-3	-1	$-\frac{1}{2}$	0	$\frac{1}{2}$	1	3
x	$g(x)$	+	-	\times	\div	=

7. Two balls are thrown in the air. The path of the first ball is represented in the graph. The second ball is released 1.5 feet higher than the first ball and after 3 seconds reaches its maximum height 5 feet lower than the first ball.

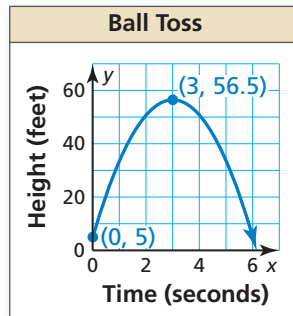

- a. Write an equation for the path of the second ball.
- b. Do the balls hit the ground at the same time? If so, how long are the balls in the air? If not, which ball hits the ground first? Explain your reasoning.
8. Let the graph of g be a translation 3 units right of the graph of f . The points $(-1, 6)$, $(3, 14)$, and $(6, 41)$ lie on the graph of f . Which points lie on the graph of g ?
- (A) $(2, 6)$ (B) $(2, 11)$ (C) $(6, 14)$
 (D) $(6, 19)$ (E) $(9, 41)$ (F) $(9, 46)$
9. Gym A charges \$10 per month plus an initiation fee of \$100. Gym B charges \$30 per month, but due to a special promotion, is not currently charging an initiation fee.
- a. Write an equation for each gym modeling the total cost y for a membership lasting x months.
- b. When is it more economical for a person to choose Gym A over Gym B?
- c. Gym A lowers its initiation fee to \$25. Describe the transformation this change represents and how it affects your decision in part (b).